

## CONTENTS

<b>General Features</b>	.....	3
<b>I/O Configuration</b>	.....	3
<b>System Configuration</b>	Higher Level Communication .....	4
	Links between PLCs .....	4
	PLC Lower Level Communications .....	5
<b>Standard Specifications</b>	Common Specifications .....	6
	Power Supply Specifications .....	7
	Functional Specifications.....	7
	Ladder Sequence Basic Instructions/ Application Instructions .....	10
<b>Module Specifications</b>	I/O Modules.....	22
	Terminal Block Unit .....	28
	YHLS Slave Units.....	28
	Standard Accessories.....	29
	Spare Parts .....	29
<b>Restrictions on Module Installation</b>	Restrictions on Module Location .....	30
	Restrictions on CPU Module Installation .....	30
	Restrictions on I/O Module Installation.....	31
<b>Current Consumption</b>	Base Modules .....	33
	Power Supply Modules .....	33
	CPU Modules.....	33
	I/O Modules.....	34
<b>Severity of Failures and LED Display</b>	Severity of Failures and LED Display.....	36
	OS-free CPU module status and output module status.....	36
<b>External Dimensions</b>	.....	37
<b>Approved / Compliant Standard</b>	.....	37
<b>Manufacturer's warranty</b>	.....	37

For information on the Discontinued Modules, refer to GS 34M06A01-99E.

---

Blank Page

**General**

The Range-free Multi-controller FA-M3 is a next-generation programmable controller, which achieves high performance through its ultra high-speed processing and stable control features. It incorporates a space-saving compact design, supports versatile ranges with cover for up to 8192 input/output points, and is equipped with a variety of advanced modules, which can be used to configure a wide range of applications.

With the FA-M3, decreased total cost of ownership (TCO) can be realized through openness, improved functions and reduction in the size of machines and facilities.

**Features**

The increased speed of the FA-M3 has been achieved as a result of adopting the concept High Speed IPRS which is based on four factors; Instruction, Process, Response and Scan. This contributed to increased accuracy of instruments and productivity. The FA-M3 has also inherited structured programming and uses an "object ladder\*" to create an efficient total design, all the way from planning to maintenance.

\*: "Object ladder" is a program development concept aimed at dramatically improving customization efficiency by integrating programs and devices into independent objects (e.g., blocks) on function basis.

● **Ultra-high Speed Processing**

The high-speed instruction processing capability of the FA-M3 makes it ideal for applications that require high speed and quick response.

- The F3SP22 CPU achieves a scan time of 1 ms for a 6K steps program\*.
- The F3SP66 and F3SP67 CPUs achieve a scan time of 1 ms for a 20K steps program\*.
- The F3SP71 and F3SP76 CPUs achieve a scan time of 1 ms for a 100K steps program\*.

\*: The scan times mentioned above can only be achieved under specific conditions and vary depending on the contents of the program and system configuration.

● **Sensor Control Function**

This function allows one CPU to perform a parallel operation at a minimum scan time of 200 μs (100 μs for F3SP7□) while carrying out a main scan during program operation. It enables one block of the program to be executed at high-speed and fixed intervals independently of a main scan, which features high performance and advanced functionalities.

● **Built-in Network Function (when using F3SP6□, F3SP7□)**

These sequence CPU modules have a built-in network function, which complements high-speed control with fast access and storage of large files. With pre-installed support for a wide range of common communication protocols, it enables transfer of large files.

● **Built-in Modbus/TCP Slave (Server) Function (when using F3SP7□)**

These sequence CPU modules have a built-in Modbus/TCP slave (server) function, which enables communication with a Modbus master (client) device via the module's communication port without need of programming on the module end.

● **Multiple CPUs**

The FA-M3 can accommodate up to 4 CPUs in one base module depending on the system size, program size and CPU aptitude. The supported CPU modules include sequence CPU modules.

● **Program Reusability**

Object ladder allows integration of programs with devices into components on function basis. This improves the reusability of user software and efficiency of machine custom design.

- **Local Device**

Devices used as variables in different user blocks or component macros are completely independent, and can be allocated to different devices even if they share the same name so that global analyses and modification of the device structure for reuse of ladders are not necessary.

● **Efficient System Maintenance (when using F3SP7□-□S)**

- **Oscilloscope-like Sampling Trace Function and Live Logic Analyzer**  
The CPU module is capable of acquiring high-speed data, which cannot be acquired using a PC. Various analysis functions, such as inter-point analysis and range adjustment are supported, enabling efficient troubleshooting when equipment fails.

● **Open Network**

The FA-M3 supports open network protocols such as Ethernet, Ethernet/IP, FL-net, DeviceNet, Modbus, GP-IB, RS-232-C/422 and Automated Distribution Protocol, and provides a range of modules for use on a variety of networks ranging from field networks to system configuration networks.



**I/O Configuration**

- **Up to Seven Additional Subunits for I/O Extension**  
Up to 8192 inputs and outputs can be processed (for F3SP67 and F3SP76).

● **Main Unit and Subunit**

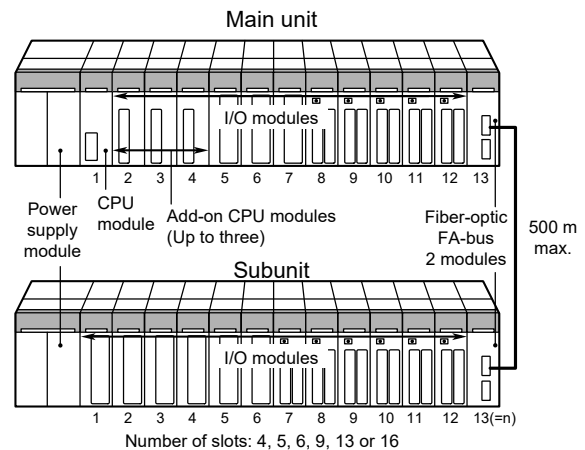

● **Subunit Extension**

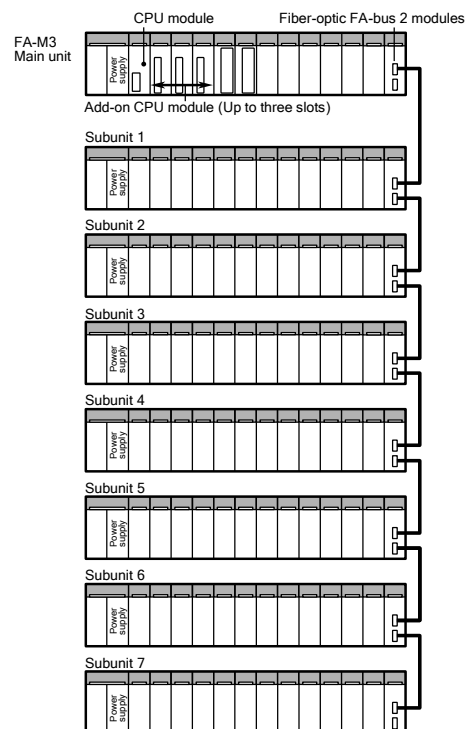

### System Configuration

#### Higher Level Communication

##### (1) Connecting to a Workstation or PC via Ethernet

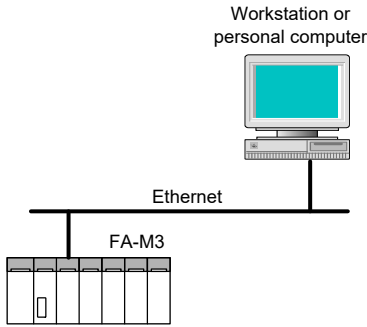

##### (2) Connecting to a Personal Computer via Public Telephone Network

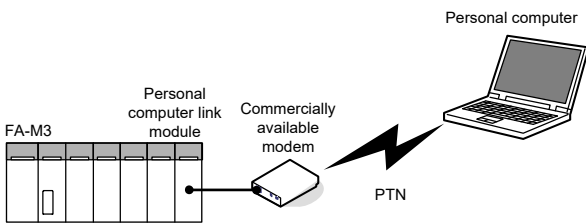

##### (3) Connecting to a Touch Operation Panel via Personal Computer Link

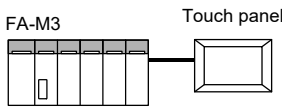

##### (4) Connecting to a Touch Operation Panel via Ethernet

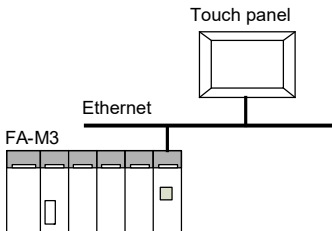

##### (5) Connecting to a Touch Operation Panel or a Personal Computer via Ethernet (Modbus/TCP protocol)

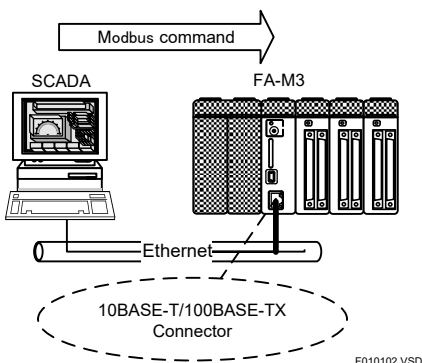

F010102.VSD

#### Links between PLCs

##### (1) Connecting between FA-M3s via FL-net (OPCN-2) modules

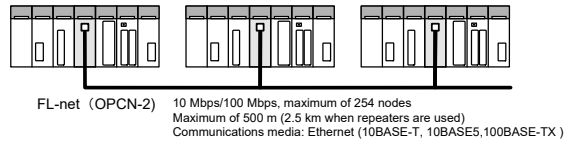

FL-net (OPCN-2) is an open, multi-vendor network, which not only allows high-speed data transfer between FA-M3 units but also connection to third-party FA controllers.

##### (2) Connecting between FA-M3s via FA link H2 modules

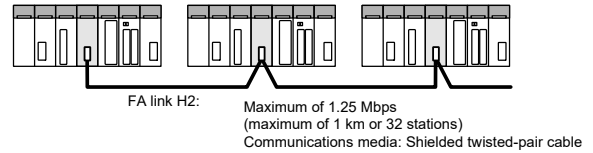

Use the FA link H2 modules for exchanging data between FA-M3s.

**■ PLC Lower Level Communications**

**(1) Adding FA-M3s via a Fiber-optic FA-bus Type 2 (remote I/O)**

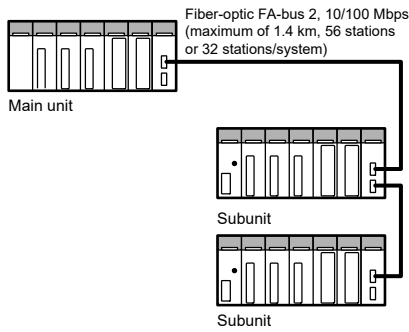

Use a fiber-optic FA-bus Type 2 module when augmenting I/O devices in a multi-station or long distance configuration.

**(2) Adding FA-M3s via a FA-bus Type 2 (remote I/O)**

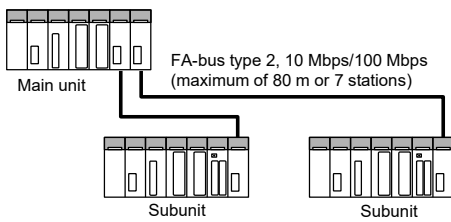

Use a FA-bus Type 2 module when adding subunits.

**(3) Connecting to YHLS Slave Units via YHLS**

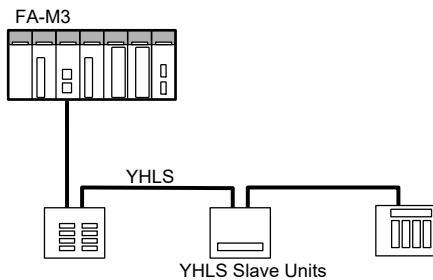

YHLS (Yokogawa Hi-speed Link System) enables easy implementation of high-speed 1:N remote I/O communication systems.

**(4) Connecting to a Temperature Controller via a UT Link**

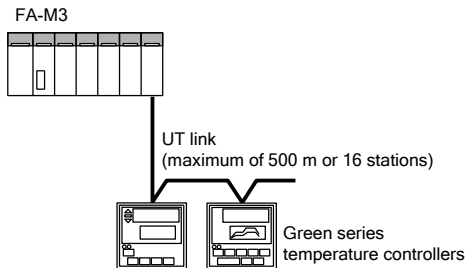

**(5) Connecting to Measuring Instruments via a GP-IB**

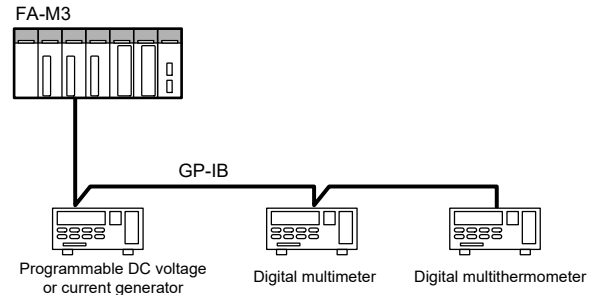

**(6) Connecting to a Barcode Reader via RS-422 Ladder Communications**

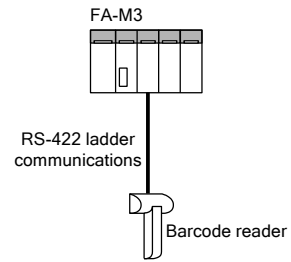

**(7) Connecting to Remote I/O and Sensors via DeviceNet**

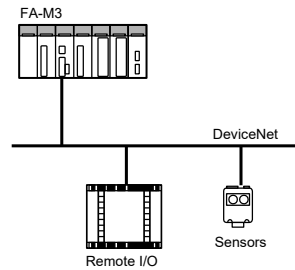

**(8) Connecting to Ethernet-enabled Equipment (sequence CPU module with built-in network functions)**

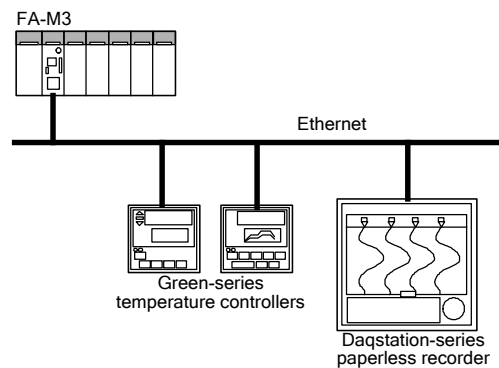

## Standard Specifications

### ■ Common Specifications

Item		Specifications		
Environment	Surrounding air temperature range	Operating : 0 to 55°C *1 Storage : -20°C to 75°C		
	Surrounding humidity range	Operating : 10 to 90% RH (non-condensing) Storage : 10 to 90% RH (non-condensing)		
	Surrounding atmosphere	Must be free of corrosive gases, flammable gases or heavy dust.		
	Grounding	AC Power supply module : Protective earth (Comply with the regulation of each country.) DC Power supply module : Functional earth		
	Noise immunity	Tested using a noise simulator with a noise voltage of 1500 Vp-p, pulse width of 1 μs, rise time of 1 ns, and repetition frequency of 25 to 60 Hz. For CE Marking-compliant modules, compliant to EN61326-1, EN61326-2-3 <sup>4</sup> and EN61000-6-2		
	Vibration resistance	Tested in compliance with JIS C60068-2-6 under the following conditions: - Frequency ranges: 10 to 57 Hz with an amplitude of 0.075 mm 57 to 150 Hz with an acceleration of 9.8 m/s <sup>2</sup> (1G) - Direction and sweep cycles: 10 times each in the X, Y, and Z directions		
	Shock resistance	Tested in compliance with JIS C60068-2-27 under the following conditions: - Direction and sweep cycles: 3 times each in the X, Y, and Z directions with an acceleration of 147 m/s <sup>2</sup> (98 m/s <sup>2</sup> with DIN-rail mounting)		
Structure & Appearance	Structure	Designed for mounting inside a panel enclosure		
	Altitude of installation	Max. of 2000 m above sea level		
	Compliance with safety and EMC standards *2	UL	UL508 approved, File No.E188707 (Overvoltage Category <sup>5</sup> : II, Pollution Degree <sup>6</sup> : 2)	
		CE	EMC Directive *3	EN 61326-1 Class A, Table 2 EN 61326-2-3 <sup>4</sup> EN 55011 Class A, Group 1 EN 61000-6-2, EN 61000-3-2, EN 61000-3-3 compliance
			Low Voltage Directive	EN 61010-1, EN 61010-2-201 compliance (Overvoltage Category <sup>5</sup> : II, Pollution Degree <sup>6</sup> : 2, Altitude: up to 2,000 m), EN 61010-2-030 compliance (Measurement Category :O) *7
		RoHS Directive*8	EN 50581 Compliance	
		RCM	EN 61326-1 Class A, Table2 EN 55011 Class A, Group1 Compliance	
	KC	Korea Electromagnetic Conformity Standard compliance		
	Cooling method	Natural-air cooled		
	Mounting	Direct mounting with M4-size setscrews *9 or DIN-rail mounting (except for F3BU16-0N module)		
Finish color	Light cobalt blue, equivalent to Munsell 6.2PB 4.6/8.8; Lampblack, equivalent to Munsell 0.8Y 2.5/0.4			
External dimensions	See the dimensional figures in "External Dimensions" of the "Hardware Manual" (IM 34M06C11-01E)			

\*1: Some FA-M3 modules may have a narrower surrounding air temperature range than 0-55°C. A system incorporating such modules must be used within the narrower surrounding air temperature range for such modules.

\*2 For details on conforming modules, see "Standard compliant products" (GS 34M06C11-21E) general specification brochure.

\*3: This product is classified as Class A for use in industrial environments. If used in a residential environment, it may cause electromagnetic interference (EMI). In such situations, it is the user's responsibility to adopt the necessary measures against EMI.

\*4: EN61326-2-3 is applicable only to F3CU04-□□.

\*5: The term Overvoltage Category involves prescriptions on resistance to surge voltage reduction due to lightning and has four categories. Overvoltage Category II applies to systems with a rated voltage of 220/230/240 V and applies to electrical appliances, portable devices, etc.

\*6: The term Pollution Degree represents the degree of pollution with foreign matter, solid, liquid or gaseous, that may produce a reduction of dielectric strength or surface resistivity in the operating environment of the equipment. Pollution degree 2 refers to an environment where normally only non-conductive pollution occurs but occasionally temporary conductivity caused by condensation is to be expected.

\*7: EN 61010-2-030 is applicable only to modules with analog input terminal. Don't use the analog input terminals of FA-M3 for measurement on Main Circuit, since those terminals have no measurement category.

\*8: 10-Substances RoHS. Phthalate ester have high migration (the property of substance transfer from other products upon contact). Therefore, care must be taken to prevent process contamination with. After unpacking each package, please control the products to prevent contamination by the customer side.

\*9: F3BU04, F3BU05, F3BU06, F3BU09 and F3BU13 each uses four mounting screws while F3BU16 uses six mounting screws.

**■ Power Supply Specifications**

Item	Specification					
	F3PU10-0S	F3PU20-0S	F3PU30-0S	F3PU16-0S	F3PU26-0S	F3PU36-0S
Supply voltage	100 V to 240 V AC, single phase, 50/60 Hz			24 V DC		
Supply voltage fluctuation range	85 V to 264 V AC, 50/60 Hz ±3 Hz			15.6 V to 31.2 V DC		
Power consumption	35 VA	85 VA	100VA	15.4 W	33.1 W	46.2 W
Inrush current	20 A max. (120 V AC, Ta = 25°C) 45 A max. (240 V AC, Ta = 25°C)			20 A max. (31.2 V DC, Ta = 25°C)		
Rated output voltage	5 V DC					
Rated output current	2.0A	4.3A	6.0A	2.0A	4.3A	6.0A
Allowable momentary power failure time	20 ms					
FAIL-signal contact output	Provided on the front terminal block on the power supply module; contact rating: 24 V DC, 0.3 A (both normally-open and normally-closed terminals available)					
Leakage current	3.5 mA max.			—		
Insulation resistance	5 MΩ or greater at 500 V DC (between external AC terminals and FG terminal)			5 MΩ or greater at 500 V DC (between external DC terminals and FG terminal)		
	5 MΩ min. when tested between a group of FAIL-signal contact output and internal circuit using a 500 VDC insulation resistance tester.					
Dielectric strength	1500 V AC for 1 minute (between external AC terminals and FG terminal)			1500 V AC for 1 minute (between external DC terminals and FG terminal)		
	1000 V AC for one minute between a group of FAIL-signal contact output and internal circuit.					

Note: F3PU□□-0S has the same dimensions, internal circuitry and other specifications as its respective F3PU□□-0N counterpart but uses screw size M4.0 instead of M3.5.

**■ Functional Specifications**

Item	Specification	
	F3SP22-0S	
Control mode	Repetitive computation based on stored programs	
I/O control mode	Refresh method/Direct I/O instructions	
Programming language	Object ladder language, mnemonic language	
Number of I/O points	4096 max	
Number of instructions	Basic instructions	37 types
	Application instructions	324 types
Instruction processing speed	Basic instructions	0.045-0.18 μs/instruction
	Application instructions	From 0.18 μs/instruction
Program size	10K steps (can be written to ROM)	
Number of program blocks	1024 max	
Sampling trace	Yes	
Link to personal computer	Yes	
Scan monitoring time	10 to 200 ms variable	
Device	Internal relay	I: 16384 max.
	Shared relay	E: 2048 max.
	Extended shared relay	E: 2048
	Link relay	L: 8192
	Special relay	M: 9984
	Timer	T: 2048 max. (2048 max. for timers and counters combined)
	Counter	C: 2048 max. (2048 max. for timers and counters combined)
	Data register	D: 16384 max.
	File register	B: 32768
	Link register	W: 8192
	Special register	Z: 1024
	Index register	V: 256
	Shared register	R: 1024 max.
	Extended shared register	R: 3072 max.

Item	Specification		
	F3SP71-4S	F3SP76-7S	
Control mode	Repetitive computation based on stored programs		
I/O control mode	Refresh method/Direct I/O instructions		
Programming language	Object ladder language		
Number of I/O points	4096 max	8192 max	
Number of instructions	Basic instructions	40 types	
	Application instructions	445 types	
Instruction processing speed	Basic instructions	From 0.00375 μs/instruction	
	Application instructions	From 0.0075 μs/instruction	
Program size	60K steps (can be written to ROM)	260K steps (can be written to ROM)	
Number of program blocks	1024 max		
Sampling trace	Yes		
Live Logic Analyzer	Yes <sup>*1</sup>		
Link to personal computer	Yes (by Ethernet only)		
Scan monitoring time	10 to 200 ms variable		
Device	Internal relay	I: 16384 max.	I: 65535 max.
	Shared relay	E: 2048 max.	
	Extended shared relay	E: 2048	
	Link relay	L: 8192	L: 16384
	Special relay	M: 9984	
	Timer	T: 2048 max. (2048 max. for timers and counters combined)	T: 3072 max. (3072 max. for timers and counters combined)
	Counter	C: 2048 max. (2048 max. for timers and counters combined)	C: 3072 max. (3072 max. for timers and counters combined)
	Data register	D: 16384 max.	D: 65535 max.
	File register	B: 32768	B: 262144
	Cache register	F: 131072	F: 524288
	Link register	W: 8192	W: 16384
	Special register	Z: 1024	
	Index register	V: 256	
	Shared register	R: 1024 max.	
	Extended shared register	R: 3072 max.	

\*1: Module Date: After Oct. 18, 2013



Item		Specification
		F3RP70-2L
CPU		Cortex-A9 MPCore (Dual 866MHz)
OS		-
Endian type		Little endian
Memory	FLASH ROM	256MB
	DDR3 SDRAM	1GB
	SRAM	8MB
I/F	Ethernet	10BASE-T / 100BASE-TX / 1000BASE-T (2ch)
	RS-232C	9.6kbps ~ 115.2kbps dedicated connector <sup>*1</sup>
	SD	SDHC memory card
	PCI	For utility module (32bit)
	JTAG	Dedicated connector
RAS function	Power Discontinuity Detection	Detects input power discontinuity, notification to application
	WDT	Monitoring application software operation status
	SD card abnormality detection	Mounted the overcurrent secured circuit
	FAIL Signal output	At abnormality detection, controls FAIL setting of power-supply module to notify exteriorly.

\*1: KM72-2N conversion cable (sold separately) is necessary

■ Ladder Sequence Basic Instructions

FUNC No	Instruction	Mnemonic	Symbol	Function	Applicable CPU	
					F3SP22-0S	F3SP71-4S F3SP76-7S
—	Load	LD		Starts a logic operation (contact a).	●	●
—	Load Not	LDN		Starts a logic NOT operation (contact b).	●	●
—	And	AND		Performs an AND (serial contact a) connection.	●	●
—	And Not	ANDN		Performs an AND NOT (serial contact b) connection.	●	●
—	Or	OR		Performs an OR (parallel contact a) connection.	●	●
—	Or Not	ORN		Performs an OR NOT (parallel contact b) connection.	●	●
—	And Load	ANDLD		Performs an AND with the preceding condition.	●	●
—	Or Load	ORLD		Performs an OR with the preceding condition.	●	●
—	Out	OUT		Generates a relay output.	●	●
07	Out Not	OUTN		Generates a NOT output.	●	●
—	Push	PUSH		Starts a branch.	●	●
—	Stack	STCRD		Branch.	●	●
—	Pop	POP		Terminates a branch.	●	●
01 / 01P	Set	SET		Set a device.	●	●
02 / 02P	Reset	RST		Resets a device.	●	●
—	Timer	TIM		Count-down timer.	●	●
—	Counter	CNT		Count-down counter.	●	●
03	Differential Up	DIFU		Causes a relay to turn on for 1 scan on the rising edge of the input signal (result of logical operation).	●	●
04	Differential Down	DIFD		Causes a relay to turn on for 1 scan on the falling edge of the input signal (result of logical operation).	●	●
05	Interlock	IL		Starts interlock.	●	●
06	Interlock Clear	ILC		Resets interlock.	●	●
00	Nop	NOP		Does nothing.	●	●
999	End	END		Terminates a scan.	●	●
301	Load Differential Up	LDU		Causes the result signal of a logical operation to turn on for 1 scan on the rising edge of the signal of a specified device.	●	●
302	Load Differential Down	LDD		Causes the result signal of a logical operation to turn on for 1 scan on the falling edge of the signal of a specified device.	●	●
303	Logical Differential Up	UP		Causes the result signal of a logical operation to turn on for 1 scan on the rising edge of the input signal (result of logical operation).	●	●
304	Logical Differential Down	DWN		Causes the result signal of a logical operation to turn on for 1 scan on the falling edge of the input signal (result of logical operation).	●	●
305	Logical Differential Up Using Specified Device	UPX		Causes the result signal of a logical operation to turn on for 1 scan on the rising edge of the input signal (result of logical operation). A specified device is used for differential operation.	●	●
306	Logical Differential Down Using Specified Device	DWNX		Causes the result signal of a logical operation to turn on for 1 scan on the falling edge of the input signal (result of logical operation). A specified device is used for differential operation.	●	●
307	Inverter	INV		Outputs inverted input signal (result of logical operation).	●	●
308	Flip-Flop	FF		Causes a relay to invert on every rising edge of an input signal.	●	●
311	Load Specified Bit	LDW		Outputs the status of a specified bit of a 16-bit data item as contact a.	●	●
311L	Load Specified Bit Long	LDW L		Outputs the status of a specified bit of a 32-bit data item as contact a.	●	●
312 / 312P	Out Specified Bit	OUTW		Outputs the result of the logical operations performed so far to a specified bit of a 16-bit data item.	●	●
312L / 312LP	Out Specified Bit Long	OUTW L		Outputs the result of the logical operations performed so far to a specified bit of a 32-bit data item.	●	●
313 / 313P	Set Specified Bit	SETW		Sets the specified bit of a 16-bit data item to ON.	●	●
313L / 313LP	Set Specified Bit Long	SETW L		Sets the specified bit of a 32-bit data item to ON.	●	●
314 / 314P	Reset Specified Bit	RSTW		Sets the specified bit of a 16-bit data item to OFF.	●	●
314L / 314LP	Reset Specified Bit Long	RSTW L		Sets the specified bit of a 32-bit data item to OFF.	●	●

Note: An instruction indicated with two FUNC Nos. can be either executed one or more times while its input condition is ON or executed only once when its input condition is ON (pulse instruction).\*

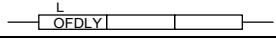
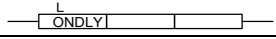
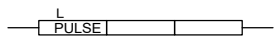
FUNC No	Instruction	Mnemonic	Symbol	Function	Applicable CPU
					F3SP71-4S F3SP76-7S
—	Off Delay	OFDLY L		Outputs OFF-delay timer operation result for a specified device	●
—	On Delay	ONDLY L		Outputs ON-delay timer operation result for a specified device	●
—	Pulse	PULSE L		Outputs pulse timer operation result for a specified device	●

■ Ladder Sequence Application Instructions

Classification	FUNC No.	Instruction	Processing Unit	Mnemonic	Symbol	Function	Applicable CPU		
							F3SP22-0S	F3SP71-4S F3SP76-7S	
Comparison	10	Compare	=	16 bits	CMP		Compares 1-word data.	●	●
			<>	16 bits				●	●
			>	16 bits				●	●
			>=	16 bits				●	●
			<	16 bits				●	●
			<=	16 bits				●	●
	10L	Compare Long	=	32 bits	CMP L		Compares 2-word data.	●	●
			<>	32 bits				●	●
			>	32 bits				●	●
			>=	32 bits				●	●
			<	32 bits				●	●
			<=	32 bits				●	●
	904	Compare Float	=	32 bits	FCMP		Compares floating point data.	●	●
			<>	32 bits				●	●
			>	32 bits				●	●
			>=	32 bits				●	●
			<	32 bits				●	●
			<=	32 bits				●	●
	111/111P	Table Compare	16 bits	BCMP		Compares 1-word data against range table.	●	●	
	111L/111LP	Table Compare Long	32 bits	BCMP L		Compares 2-word data against range table.	●	●	
	919/919P	Table Compare Float	32 bits	FBCP L		Compares floating-point data against range table.	●	●	
112/112P	Table Search	16 bits	TSRCH		Searches for 1-word data in table.	●	●		
112L/112LP	Table Search Long	32 bits	TSRCH L		Searches for 2-word data in table.	●	●		
Arithmetic	20/20P	Add	16 bits	CAL		Adds 1-word data.	●	●	
		Subtract	16 bits			Subtracts 1-word data.	●	●	
		Multiply	16 bits			Multiplies 1-word data.	●	●	
		Divide	16 bits			Divides 1-word data.	●	●	
	20L/20LP	Add Long	32 bits	CAL L		Adds 2-word data.	●	●	
		Subtract Long	32 bits			Subtracts 2-word data.	●	●	
		Multiply Long	32 bits			Multiplies 2-word data.	●	●	
		Divide Long	32 bits			Divides 2-word data.	●	●	
	903/903P	Add Float	32 bits	FCAL L		Adds floating-point data.	●	●	
		Subtract Float	32 bits			Subtracts floating-point data.	●	●	
		Multiply Float	32 bits			Multiplies floating-point data.	●	●	
		Divide Float	32 bits			Divides floating-point data.	●	●	

Note: An instruction indicated with two FUNC Nos. can be either executed one or more times while its input condition is ON or executed only once when its input condition is ON (pulse instruction).

Classification	FUNC No.	Instruction	Processing Unit	Mnemonic	Symbol	Function	Applicable CPU	
							F3SP22-0S	F3SP71-4S F3SP76-7S
Arithmetic (cont.)	120/120P	Increment	16 bits	INC		Adds 1 to 1-word data.	●	●
	120L/120LP	Increment Long	32 bits	INC L		Adds 1 to 2-word data.	●	●
	121/121P	Decrement	16 bits	DEC		Subtracts 1 from 1-word data.	●	●
	121L/121LP	Decrement Long	32 bits	DEC L		Subtracts 1 from 2-word data.	●	●
	122/122P	Square Root	16 bits	SQR		Computes square root of 1-word data.	●	●
	122L/122LP	Square Root Long	32 bits	SQR L		Computes square root of 2-word data.	●	●
	915/915P	Square Root Float	32 bits	FSQR		Computes square root of floating-point data.	●	●
	907/907P	SIN	32 bits	FSIN L		Computes the sine of a radian angle as a floating-point (SIN) number.	●	●
	908/908P	COS	32 bits	FCOS L		Computes the cosine of a radian angle as a floating-point (COS) number.	●	●
	909/909P	TAN	32 bits	FTAN L		Computes the tangent of a radian angle as a floating-point (TAN) number.	●	●
	910/910P	SIN <sup>-1</sup>	32 bits	FASIN L		Computes the arc sine of a floating-point number in radians (SIN <sup>-1</sup> ).	●	●
	911/911P	COS <sup>-1</sup>	32 bits	FACOS L		Computes the arc cosine of a floating-point number in radians (COS <sup>-1</sup> ).	●	●
	912/912P	TAN <sup>-1</sup>	32 bits	FATAN L		Computes the arc tangent of a floating-point number in radians (TAN <sup>-1</sup> ).	●	●
	913/908P	LOG	32 bits	FLOG L		Computes the logarithm of floating-point data.	●	●
914/914P	EXP	32 bits	FEXPL		Computes the exponential of floating-point data.	●	●	
Logical	20 /20P	Logical AND	16 bits	CAL		Performs AND operation on 1-word data.	●	●
		Logical OR	16 bits			Performs OR operation on 1-word data.	●	●
		Logical XOR	16 bits			Performs XOR operation on 1-word data.	●	●
		Logical NXOR	16 bits			Performs NXOR operation on 1-word data.	●	●
	20L /20LP	Logical AND Long	32 bits	CAL L		Performs AND operation on 2-word data.	●	●
		Logical OR Long	32 bits			Performs OR operation on 2-word data.	●	●
		Logical XOR Long	32 bits			Performs XOR operation on 2-word data.	●	●
		Logical NXOR Long	32 bits			Performs NXOR operation on 2-word data.	●	●
	21 /21P	Two's Complement	16 bits	NEG		Calculate two's complement of 1-word data (inverts sign).	●	●
	21L /21LP	Two's Complement Long	32 bits	NEG L		Calculate two's complement of 2-word data (inverts sign).	●	●
22 /22P	NOT	16 bits	NOT		Inverts all bits of 1-word data.	●	●	
22L /22LP	NOT Long	32 bits	NOT L		Inverts all bits of 2-word data.	●	●	
Rotate	30 /30P	Right Rotate	16 bits	RROT		Rotates 1 word right by 1 bit.	●	●
	30L /30LP	Right Rotate Long	32 bits	RROT L		Rotates 2 words right by 1 bit.	●	●
	130 /130P	Right Rotate with Carry	16 bits	RROTC		Rotates 1 word right by 1 bit (with carry).	●	●
	130L /130LP	Right Rotate with Carry Long	32 bits	RROTC L		Rotates 2 words right by 1 bit (with carry).	●	●
	31 /31P	Left Rotate	16 bits	LROT		Rotates 1 word left by 1 bit.	●	●
	31L /31LP	Left Rotate Long	32 bits	LROT L		Rotates 2 words left by 1 bit.	●	●
	131/131P	Left Rotate with Carry	16 bits	LROTC		Rotates 1 words left by 1 bit (with carry).	●	●
131L/131LP	Left Rotate with Carry Long	32 bits	LROTC L		Rotates 2 words left by 1 bit (with carry).	●	●	

Note: An instruction indicated with two FUNC Nos. can be either executed one or more times while its input condition is ON or executed only once when its input condition is ON (pulse instruction).

Classification	FUNC No.	Instruction	Processing Unit	Mnemonic	Symbol	Function	Applicable CPU	
							F3SP22-0S	F3SP71-4S F3SP76-7S
Shift	32 /32P	Right Shift	16 bits	RSFT		Shifts 1 word right by 1 bit.	●	●
	32L /32LP	Right Shift Long	32 bits	RSFT L		Shifts 2 words right by 1 bit.	●	●
	132/132P	Right Shift m-bit Data by n bits	—	RSFTN		Shifts data of specified bit length right by a specified number of bits.	●	●
	33 /33P	Left Shift	16 bits	LSFT		Shifts 1 word left by 1 bit.	●	●
	33L /33LP	Left Shift Long	32 bits	LSFT L		Shifts 2 words left by 1 bit.	●	●
	133/133P	Left Shift m-bit Data by n bits	—	LSFTN		Shifts data of specified bit length left by a specified number of bits.	●	●
	34	Shift Register	—	SFTR		Shifts data of specified bit length left and right by 1-bit position.	○	○
Data Transfer	40 /40P	Move	16 bits	MOV		Moves 1-word data.	●	●
	40L /40LP	Move Long	32 bits	MOV L		Moves 2-word data.	●	●
	41 /41P	Partial Move	16 bits	PMOV		Moves specified part of 1-word data.	●	●
	42 /42P	Block Move	16 bits	BMOV		Moves n-word data.	●	●
	43 /43P	Block Set	16 bits	BSET		Sets data into n words.	●	●
	44 /44P	Right word Shift	16 bits	RWS		Shifts word right.	●	●
	45 /45P	Left Word Shift	16 bits	LWS		Shifts word left.	●	●
	46 /46P	Indexed Move	16 bits	IXMOV		Moves 1-word data with index.	●	●
	46L /46LP	Indexed Move Long	32 bits	IXMOV L		Moves 2-word data with index.	●	●
Data Transfer	47 /47P	Exchange	16 bits	XCHG		Exchanges 1-word data.	●	●
	47L /47LP	Exchange Long	32 bits	XCHG L		Exchanges 2-word data.	●	●
	140/140P	Negated Move	16 bits	NMOV		Moves 1-word data with inversion.	●	●
	140L/140LP	Negated Move Long-word	32 bits	NMOV L		Moves 2-word data with inversion.	●	●
	141/141P	Extended Partial Move	16 bits max.	PMOVX		Moves specified part of 1-word data.	●	●
	142/142P	Bit Move	16 bits	BITM		Moves 1 bit.	●	●
	143/143P	Digit Move	16 bits	DGTM		Moves a specified digit of 1-word data.	●	●
Data Processing	50 /50P	FIFO Read	16 bits	FIFRD		Reads FIFO table.	●	●
	51 /51P	FIFO Write	16 bits	FIFWR		Writes FIFO table.	●	●
	52 /52P	Binary Conversion	16 bits	BIN		Converts 1-word data from BCD code to BIN code.	●	●
	52L /52LP	Binary Conversion Long	32 bits	BIN L		Converts 2-word data from BCD code to BIN code.	●	●
	53 /53P	BCD Conversion	16 bits	BCD		Converts 1-word data from BIN code to BCD code.	●	●
	53L /53LP	BCD Conversion Long	32 bits	BCD L		Converts 2-word data from BIN code to BCD code.	●	●
	916/916P	Float to BCD	32 bits	FBCD L		Converts floating-point data to BCD.	●	●
	917/917P	BCD to Float	32 bits	BCDF L		Converts BCD to floating-point data.	●	●
	901/901P	Integer to Float	16 bits	ITOF		Converts 1-word integer to floating-point data.	●	●
	901L/901LP	Long Integer to Float	32 bits	ITOF L		Converts 2-word integer to floating-point data.	●	●
	902/902P	Float to Integer	16 bits	FTOI		Converts floating-point data to 1-word integer.	●	●
	902L/902LP	Float to Long Integer	32 bits	FTOI L		Converts floating-point data to 2-word integer.	●	●

Note: An instruction indicated with two FUNC Nos. can be either executed one or more times while its input condition is ON or executed only once when its input condition is ON (pulse instruction).  
An instruction indicated with "○" is executed only once when its input condition is ON

Classification	FUNC No.	Instruction	Processing Unit	Mnemonic	Symbol	Function	Applicable CPU	
							F3SP22-0S	F3SP71-4S F3SP76-7S
Data Processing (cont.)	905/905P	Convert Degree to Radian	32 bits	FRAD L		Converts degree (floating-point) data to radian (floating-point) data.	●	●
	906/906P	Convert Radian to Degree	32 bits	FDEG L		Converts radian (floating-point) data to degree (floating-point) data.	●	●
	54 /54P	7-Segment Decoder	16 bits	SEG		Decodes to 7-segment LED data.	●	●
	55 /55P	Convert ASCII	16 bits	ASC		Converts to ASCII data.	●	●
	56 /56P	Bit set	16 bits	BITS		Sets bit of 1-word data.	●	●
	56L/56LP	Bit Set Long	32 bits	BITS L		Sets bit of 2-word data.	●	●
	57 /57P	Bit Reset	16 bits	BITR		Resets bit of 1-word data.	●	●
	57L/57LP	Bit Reset Long	32 bits	BITR L		Resets bit of 2-word data.	●	●
	151/151P	Carry Set	—	CSET		Sets carry flag.	●	●
	152/152P	Carry Reset	—	CRST		Resets carry flag.	●	●
	153/153P	Distribute Data	16 bits	DIST		Distributes 1-word data into 4-bit segments.	●	●
	153L/153LP	Distribute Data Long	32 bits	DIST L		Distributes 2-word data into 4-bit segments.	●	●
	154/154P	Unit Data	16 bits	UNIT		Extracts 4-bit data from 4-word data.	●	●
	154L/154LP	Unit Data Long	32 bits	UNIT L		Extracts 4-bit data from 8-word data.	●	●
	155/155P	Decode	16 bits	DECO		Decodes 8-bit data into 256-bit data.	●	●
	156/156P	Encode	16 bits	ENCO		Decodes 256-bit data into 8-bit data.	●	●
	157/157P	Bit Counter	16 bits	BCNT		1-word bit counter	●	●
	157L/157LP	Bit Counter Long	32 bits	BCNT L		2-word bit counter	●	●
	158/158P	Approximate Broken Line	16 bits	APR		Approximates 1-word line segment.	●	●
	158L/158LP	Approximate Broken Line Long	32 bits	APR L		Approximates 2-word line segment.	●	●
918/918P	Float Approximate Broken Line	32 bits	FAPR L		Approximates floating-point line segment.	●	●	
951/951P	Extend Sign	32 bits	SIGN L		Provides sign extension.	●	●	
Refresh	60 /60P	Direct Refresh	16 bits	DREF		Refreshes I/O relay.	●	●
Program Control	61 /61P	Jump	—	JMP		Causes a jump to a specified location.	●	●
	62 /62P	Subroutine Call	—	CALL		Calls a subroutine.	●	●
	63	Subroutine Entry	—	SUB		Begins a subroutine.	●	●
	64	Subroutine Return	—	RET		Ends a subroutine.	●	●
	65	Interrupt	—	INTP		Starts interrupt processing.	●	●
	66	Interrupt Return	—	IRET		Returns from interrupt processing.	●	●
	67	Disable Interrupt	—	DI		Disables interrupts.	●	●
	68	Enable Interrupt	—	EI		Enables interrupts.	●	●
	69 /69P	Activate Block	—	ACT		Activates a block.	●	●
	70 /70P	Inactivate Block	—	INACT		Inactivates a block.	●	●
	71 /71P	Activate Sensor Control Block	—	CBACT		Activates a sensor control block.	●	●
	72 /72P	Inactivate Sensor Control Block	—	CBINA		Inactivates a sensor control block.	●	●
	73	Disable Sensor Control Block	—	CBD		Disables a sensor control block.	●	●
	74	Enable Sensor Control Block	—	CBE		Enables a sensor control block.	●	●

Note: An instruction indicated with two FUNC Nos. can be either executed one or more times while its input condition is ON or executed only once when its input condition is ON (pulse instruction).

Classification	FUNC No.	Instruction	Processing Unit	Mnemonic	Symbol	Function	Applicable CPU	
							F3SP22-0S	F3SP71-4S F3SP76-7S
Program Control (cont.)	160	For Loop	—	FOR	FOR	Begins a loop.	●	●
	161	Next Loop	—	NEXT	NEXT	Ends a loop.	●	●
	162	Break Loop	—	BRK	BRK	Breaks a FOR-NEXT loop.	●	●
	280P	Signal to BASIC	—	SIG	SIG	Signals an interrupt to BASIC.	○	○
Special Module	81 /81P	Read	16 bits	READ	READ	Reads a special module in 1-word units.	●	●
	81L /81LP	Read Long	32 bits	READ L	L READ	Reads a special module in 2-word units.	●	●
	82 /82P	Write	16 bits	WRITE	WRITE	Writes a special module in 1-word units.	●	●
	82L /82LP	Write Long	32 bits	WRITE L	L WRITE	Writes a special module in 2-word units.	●	●
	83 /83P	High-speed Read	16 bits	HRD	HRD	Reads a special module in 1-word units at high speed.	●	●
	83L /83LP	High-speed Read Long	32 bits	HRD L	L HRD	Reads a special module in 2-word units at high speed.	●	●
	84 /84P	High-speed Write	16 bits	HWR	HWR	Writes a special module in 1-word units at high speed.	●	●
	84L /84LP	High-speed Write Long	32 bits	HWR L	L HWR	Writes a special module in 2-word units at high speed.	●	●
String Manipulation	931/931P	String to Number	16 bits	VAL	VAL	Converts character string data into numeric data.	●	●
	931L/931LP	String to Long Number	32 bits	VAL L	L VAL	Converts character string data into long-word numeric data.	●	●
	932/932P	Number to String	16 bits	STR	STR	Converts numeric data into character string data.	●	●
	932L/932LP	Long Number to String	32 bits	STR L	L STR	Converts long-word numeric data into character string data.	●	●
	933/933P	String Chain	8 bits	SCHN	SCHN	Concatenates character strings.	●	●
	934/934P	String Move	8 bits	SMOV L	L SMOV	Moves character strings.	●	●
	935/935P	String Length Count	8 bits	SLEN	SLEN	Counts the length of a character string.	●	●
	936/936P	Compare String	8 bits	SCMP	SCMP	Compares character strings.	●	●
	937/937P	String Middle	8 bits	SMID	SMID	Extracts a substring from a character string.	●	●
	938/938P	String Left	8 bits	SLFT	SLFT	Extracts a substring from the left of a character string.	●	●
	939/939P	String Right	8 bits	SRIT	SRIT	Extracts a substring from the right of a character string.	●	●
	940/940P	String Search	8 bits	SIST	SIST	Searches for a character string.	●	●
Structure and Macro	986	Structure Pointer Declaration	—	STRCT	STRCT	Declares the type of structures to be passed.	●	●
	987	Structure Move	—	STMOV	STMOV	Moves structures.	●	●
	982/982P	Structure Macro Instruction Call	1/16	SCALL	S cccccccc	Executes a registered structure macro instruction.	●	●
	996/996P	Macro Call	1/16/32	MCALL	M cccccccc	Transfers control to a specified macro instruction.	●	●
	995/995P	Parameter	1/16/32	PARA	PARA	Passes parameters to a macro instruction or an input macro.	●	●
	998	Macro Return	—	MRET	MRET	Designates the end of a macro instruction, input macro instruction, or structure macro instruction.	●	●
	981	Input Macro Instruction Call	1/16/32	NCALL	N cccccccc	Executes a registered macro instruction.	●	●
	309/309P	Output of Input Macro	1/16	NMOUT	NMOUT	Specifies the logical operation result of an input macro instruction.	●	●

Note: An instruction indicated with two FUNC Nos. can be either executed one or more times while its input condition is ON or executed only once when its input condition is ON (pulse instruction).  
An instruction indicated with "○" is executed only once when its input condition is ON



Classification	FUNC No.	Instruction	Processing Unit	Mnemonic	Symbol	Function	Applicable CPU	
							F3SP22-0S	F3SP71-4S F3SP76-7S
Indirect Specification	510/510P	Indirect Address Set	3 bits	SET@	— <input type="text" value="SET@"/> —	Stores the value representing a device address as three-word data.	●	●
	511/511P	Indirect Address Add	2 bits	ADD@	— <input type="text" value="ADD@"/> —	Adds a long-word value to an address and stores the result as 3-word data.	●	●
	512/512P	Indirect Address Move	3 bits	MOV@	— <input type="text" value="MOV@"/> —	Transfers an indirect address stored as 3-word data.	●	●
Watchdog	85 /85P	Refresh Watchdog Timer	—	WDT	— <input type="text" value="WDT"/> —	Refreshes a watchdog timer.	●	●
Free Run Timer	186/186P	Read Free Run Timer	16 bits	FTIMR	— <input type="text" value="FTIMR"/> —	Reads free-run timer of CPU module	●	●
Trace	181/181P	Sampling Trace	1 bit 16 bits	TRC	— <input type="text" value="TRC"/> —	Acquires sampling trace data and Live Logic Analyzer*1 data.	●	●
User Log	961/961P	Save User Log	8 bits	ULOG	— <input type="text" value="ULOG"/> —	Stores user log.	●	●
	962/962P	Read User Log	8 bits	ULOGR	— <input type="text" value="ULOGR"/> —	Reads user log.	●	●
	963/963P	Clear User Log	8 bits	UCLR	— <input type="text" value="UCLR"/> —	Clears user log.	●	●
Date and Time	520P	Set Date	3 bits	DATE	— <input type="text" value="DATE"/> —	Sets the date of the sequence CPU module.	○	○
	521P	Set Time	3 bits	TIME	— <input type="text" value="TIME"/> —	Sets the time of the sequence CPU module.	○	○
	522P	Set Date String	8 bits	SDATE	— <input type="text" value="SDATE"/> —	Sets the date of the sequence CPU module using a specified date string.	○	○
	523P	Set Time String	8 bits	STIME	— <input type="text" value="STIME"/> —	Sets the time of the sequence CPU module using a specified time string.	○	○

Note: An instruction indicated with two FUNC Nos. can be either executed one or more times while its input condition is ON or executed only once when its input condition is ON (pulse instruction).  
An instruction indicated with "○" is executed only once when its input condition is ON.

\*1: Live Logic Analyzer is compatible with only F3SP71-4S and F3SP76-7S.

■ Ladder Sequence Continuous Type Application Instructions

Classification	FUNC No.	Instruction	Processing Unit	Mnemonic	Symbol	Function	Applicable CPU
							F3SP71-4S F3SP76-7S
Disk Operation	—	Mount Memory Card	—	MOUNT		Mounts a memory card.	●
	—	Unmount Memory Card	—	UNMOUNT		Unmounts a memory card.	●
	—	Format Disk	—	FORMAT		Formats a memory card or RAM disk.	●
	—	Disk Info	—	DISKINFO		Gets information about a specified disk.	●
File Access	—	Open File	16 bits	FOPEN		Opens a file.	●
	—	Close File	16 bits	FCLOSE		Closes a file.	●
	—	Read File Line	8 bits	FGETS		Reads one line from a file.	●
	—	Write File Line	8 bits	FPUTS		Writes one line to a file.	●
	—	Read File Block	8 bits	FREAD		Reads data of specified size from a file.	●
	—	Write File Block	8 bits	FWRITE		Writes data of specified size to a file.	●
	—	File Seek	8 bits	FSEEK		Moves the file pointer of a file.	●
	—	File Text Search	8 bits	FSEARCH T		Finds a specified string in a file.	●
	—	File Binary Search	8 bits	FSEARCH B		Finds specified binary data in a file.	●
	—	Convert CSV File to Device	—	F2DCSV		Converts a CSV formatted file into device data.	●
	—	Convert Device to CSV File	—	D2FCSV		Converts device data into a CSV formatted file.	●
	—	Convert Binary File to Device	—	F2DBIN		Converts a binary file into device data.	●
	—	Convert Device to Binary File	—	D2FBIN		Converts device data into a binary file.	●
	File Operation	—	Copy File	—	FCOPY		Copies one or more files.
—		Move File	—	FMOVE		Moves one or more files.	●
—		Delete File	—	FDEL		Deletes one or more files.	●
—		Make Directory	—	FMKDIR		Creates a directory.	●
—		Remove Directory	—	FRMDIR		Deletes a directory.	●
—		Rename File	—	FREN		Renames a file or directory.	●
—		File Status	—	FSTAT		Gets status information of a file or directory.	●
—		File List Start	—	FLSFIRST		Declares a file list operation for getting file status information.	●
—		File List Next	—	FLS		Gets status of the next file in a file list operation.	●
—		File List End	—	FLSFIN		Declares the end of a file list operation.	●
—		Change Directory	—	FCD		Changes the current directory.	●
—		Concatenate File	—	FCAT		Concatenates two files.	●
—		Change File Attribute	—	FATRW		Changes the attribute of a specified file or directory.	●

Classification	FUNC No.	Instruction	Processing Unit	Mnemonic	Symbol	Function	Applicable CPU
							F3SP71-4S F3SP76-7S
UDP/IP Socket Communications	—	UDP/IP Open	—	UDPOPEN		Opens a UDP/IP socket.	●
	—	UDP/IP Close	—	UDPCLOSE		Closes a UDP/IP socket.	●
	—	UDP/IP Send Request	8 bits	UDPSND		Sends data from a using UDP/IP socket.	●
	—	UDP/IP Receive Request	8 bits	UDPRCV		Receives data from a UDP/IP socket to device.	●
TCP/IP Socket Communications	—	TCP/IP Open	—	TCPOPEN		Opens a TCP/IP socket.	●
	—	TCP/IP Close	—	TCPCLOSE		Closes a TCP/IP socket.	●
	—	TCP/IP Connect Request	—	TCPCNCT		Issues a connection request to a TCP/IP server.	●
	—	TCP/IP Listen Request	—	TCPLISN		Waits for a connection request from a TCP/IP client.	●
	—	TCP/IP Send Request	8 bits	TCPSND		Sends data using TCP/IP socket.	●
	—	TCP/IP Receive Request	8 bits	TCPRCV		Receives data from a TCP/IP socket to device.	●
FTP Client	—	FTP Client Open	—	FTPOPEN		Runs FTP client.	●
	—	FTP Client Quit	—	FTPQUIT		Exits from FTP client.	●
	—	FTP Client Put File	—	FTPPUT		Transfers a file to FTP server.	●
	—	FTP Client Put Unique File	—	FTPPUTU		Transfers a file to FTP server to be stored with a unique filename determined automatically by the server.	●
	—	FTP Client Append File	—	FTPAPEND		Transfers a file to FTP server to be appended to a specified file.	●
	—	FTP Client Get File	—	FTPGET		Gets a file from FTP server.	●
	—	FTP Client Change Directory	—	FTPCD		Changes current directory on FTP server.	●
	—	FTP Client Change Local Directory	—	FTPLCD		Changes local current directory on FTP client.	●
	—	FTP Client Current Directory Info	—	FTPPWD		Gets information about current directory of FTP server.	●
	—	FTP Client Get File List	—	FTPLS		Gets directory/file information from FTP server.	●
	—	FTP Client Delete File	—	FTPDEL		Deletes one or more files on FTP server.	●
	—	FTP Client Rename File	—	FTPREN		Renames a file on FTP server.	●
	—	FTP Client Make Directory	—	FTPMKDIR		Creates a directory on FTP server.	●
	—	FTP Client Remove Directory	—	FTPRMDIR		Deletes a directory on FTP server.	●
—	FTP Client Representation Type	—	FTPTYPE		Selects ASCII or binary for FTP data transfer.	●	
FTP Server	—	FTP Server Run Request Service	—	FTPSRUN		Resumes FTP server request service.	●
	—	FTP Server Stop Request Service	—	FTPSSTOP		Stops FTP server request service.	●
Miscellaneous	—	Write CPU Properties	—	PWRITE		Writes CPU property values.	●
	—	Read CPU Properties	—	PREAD		Reads CPU property values.	●

■ 64-bit Arithmetic and Comparison Instructions

Classification	FUNC No.	Instruction	Processing Unit	Mnemonic	Symbol	Function	Applicable CPU	
							F3SP71-4S F3SP76-7S	
Comparison	10D	Compare Double	=	64 bits	CMP D		Compares 4-word data.	●
			<>	64 bits				●
			>	64 bits				●
			>=	64 bits				●
			<	64 bits				●
			<=	64 bits				●
			904E	Compare Float Double		=		64 bits
	<>	64 bits				●		
	>	64 bits				●		
	>=	64 bits				●		
	<	64 bits				●		
	<=	64 bits				●		
	Arithmetic	20D			Add Double	64 bits	CAL D	
			Subtract Double	64 bits		Subtracts 4-word data.		●
Multiply Double			64 bits		Multiplies 4-word data.	●		
Divide Double			64 bits		Divides 4-word data.	●		
903E		Add Double Float	64 bits	FCAL E		Adds double-precision floating-point data.	●	
		Subtract Double Double	64 bits			Subtracts double-precision floating-point data.	●	
		Multiply Double Float	64 bits			Multiplies double-precision floating-point data.	●	
		Divide Double Float	64 bits			Divides double-precision floating-point data.	●	
122D		Square Root Double	64 bits	SQR D		Computes square root of 4-word data.	●	
915E		Square Root Double Float	64 bits	FSQR E		Computes square root of double-precision floating-point data.	●	
Data Transfer	40D	Move Double	64 bits	MOV D		Moves 4-word data.	●	
Data Processing	951D	Extend Sign Double	64 bits	SIGN D		Extends sign of long-word data to double-word data	●	
	920L	Long Integer to Double Float	32 bits	ITOE L		Converts 2-word integer to double-precision floating-point data.	●	
	921D	Double Long Integer to Double Float	64 bits	ITOE D		Converts 4-word integer to double-precision floating-point data.	●	
	922L	Double Float to Long Integer	32 bits	ETOI L		Converts double-precision floating-point data to 2-word integer	●	
	923D	Double Float to Double Long Integer	64 bits	ETOI D		Converts double-precision floating-point data to 4-word integer	●	
	925F	Float to Double Float	32 bits	FTOE		Converts floating-point data to double-precision floating-point data.	●	
	926E	Double Float to Float	64 bits	ETOF E		Converts double-precision floating-point data to floating-point data.	●	
Elapsed Timer	965	Start Elapsed Timer (TMS)	32 bits	TMS L		Start elapsed timer and stores the free-run timer value into a specified device	●	
	966	Elapsed Time (TME)	32 bits	TME L		Stores result of elapsed time since timer is started by TMS into a specified device	●	

■ Ladder Sequence Application Instructions

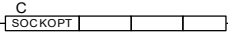
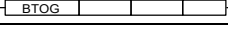
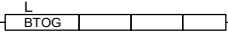
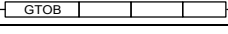
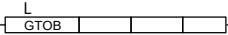
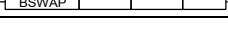
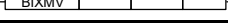
Classi- fication	FUNC No.	Instruction	Processing Unit	Mnemonic	Symbol	Function	Applicable CPU
							F3SP71-4S F3SP76-7S
TCP/IP Socket Communications	—	Socket Option	—	SOCKOPT		Sets socket option	●
Data Processing	58/58P	Binary to Gray	16 bits	BTOG		Converts binary code to Gray code	●
	58L/ 58LP	Long Binary to Gray	32 bits	BTOG L		Converts 2-word binary code to 2-word Gray code	●
	59/ 59P	Gray to Binary	16 bits	GTOB		Converts Gray code to binary code	●
	59L/ 59LP	Long Gray to Binary	32 bits	GTOB L		Converts 2-word Gray code to 2-word binary code	●
Data Transfer	48/48P	Block Swap and Move	16 bits	BSWAP		Performs 8-bit swap for each word and moves n words	●
	49/49P	Byte Indexed Move	8 bits	BIXMV		Moves n words from byte offset position of source to byte offset position of destination	●

Note: An instruction indicated with two FUNC Nos. can be either executed one or more times while its input condition is ON or executed only once when its input condition is ON (pulse instruction).

## Module Specifications

### I/O Modules

#### Digital I/O

Model	Input Type	Number of Points	Isolation Method	Rated Input Voltage	Rated Input Current	Operating Voltage/Current		Input Response Time		External Connection	Number of Points/Common
						ON	OFF	OFF→ON	ON→OFF		
F3XH04-3N	DC voltage	4	Photocoupler isolation	24V DC	11.2 mA/point	16.0 V DC min. 7.2 mA min.	6.0 V DC max. 2.5 mA max.	50 μs max.	50 μs max.	10-point terminal block M3.5 screw	All points independent
F3XA08-1N	AC voltage	8		100-120V AC 50/60Hz	5.4-6.5 mA/point 100-120 V AC, 60 Hz	80 V AC min. 5 mA min.	40 V AC max. 1 mA max.	15 ms max or 30 ms., selectable	25 ms max. or 40 ms, selectable	10-point terminal block M3.5 screw	8 points/common
F3XA08-2N				200-240V AC 50/60Hz	5.1-6.1 mA/point 200-240 V AC, 60 Hz	160 V AC min. 4 mA min.	70 V AC max. 1 mA max.				
F3XA16-1N	DC voltage (sink/ source)	16		100-120V AC 50/60Hz	5.4-6.5 mA/point 100-120 V AC, 60 Hz	80 V AC min. 5 mA min.	40 V AC max. 1 mA max.	Input sampling time can be specified for 5steps: Always (0μs), 62.5μs, 250μs, 1ms, and 16ms <sup>*1,2</sup>	Input sampling time can be specified for 5steps: Always (0μs), 62.5μs, 250μs, 1ms, and 16ms <sup>*1,2</sup>	18-point terminal block M3.5 screw	8 points/common
F3XD08-6F				12-24V DC	4.1 mA/point (12 V DC) 8.5 mA/point (24 V DC)	8.0 V DC min. 2.6 mA min.	3.4 V DC max. 1.0 mA max.				
F3XD16-3F	DC voltage (sink/ source)	16		24V DC	4.1 mA/point 24 V DC	16.0 V DC min. 3.2 mA min.	5.8 V DC max. 0.9 mA max.	Input sampling time can be specified for 4 steps: Always (0μs), 62.5μs, 250μs and 1ms <sup>*1,2</sup> .	Input sampling time can be specified for 4 steps: Always (0μs), 62.5μs, 250μs and 1ms <sup>*1,2</sup> .	18-point terminal block M3.5 screw	8 points/common
F3XD16-4F				12V DC	4.1 mA/point 12 V DC	8.0 V DC min. 2.6 mA min.	3.4 V DC max. 1.0 mA max.				
F3XD32-3F		32		24V DC	4.1 mA/point 24 V DC	16.0 V DC min. 3.2 mA min.	5.8 V DC max. 0.9 mA max.			Two 40-pin connectors	8 points/common
F3XD32-4F				12V DC	4.1 mA/point 12 V DC	8.0 V DC min. 2.6 mA min.	3.4 V DC max. 1.0 mA max.				
F3XD32-5F				5V DC	4.0 mA/point 5 V DC	3.5 V DC min. 2.0 mA min.	1.0 V DC max. 0.2 mA max.				
F3XD64-3F				64	24V DC	4.1 mA/point 24 V DC	16.0 V DC min. 3.2 mA min.				
F3XD64-4F	12V DC	4.1 mA/point 12 V DC			8.0 V DC min. 2.6 mA min.	3.4 V DC max. 1.0 mA max.					
F3XD64-6M	DC voltage (matrix scan)	64		12-24V DC	3.9 mA/point (12 V DC) 8.2 mA/point (28 V DC)	8.0 V DC min. 2.6 mA min.	3.4 V DC max. 1.0 mA max.	16 ms max	16 ms max.	One 40-pin connector	8 × 8 matrix
F3XD16-3H	DC voltage (plus common)	16	24V DC	4.7 mA/point 24 V DC	16.0 V DC min. 3.2 mA min.	5.8 V DC max. 0.9 mA max.	Input sampling time can be specified for 5steps: Always (0μs), 62.5μs, 250μs, 1ms, and 16ms <sup>*1,2</sup>	Input sampling time can be specified for 5steps: Always (0μs), 62.5μs, 250μs, 1ms, and 16ms <sup>*1,2</sup>	18-point terminal block M3.5 screw	8 points/common	

\*1: Indicated values apply to F3SP22, F3SP28, F3SP38, F3SP53, F3SP58, F3SP59, F3SP66, F3SP67, F3SP71 and F3SP76. When other CPU modules are used, the specifications are the same as F3XD□□-□□N. The actual response time can be obtained by adding the following values:

For F3XD□□-□□F: 100 μs (OFF → ON)  
300 μs (ON → OFF)  
For F3XD16-3H: 10 μs

\*2: If the input interrupt is to be used with the F3XD□□-□□F, set the input sampling period to at least 62.5 μs.

Model	Input Type	Number of Points	Isolation Method	Contact Rating	ON Resistance	OFF Resistance	Input Response Time		External Connection	Number of Points/Common
							OFF→ON	ON→OFF		
F3XC08-0N	No-voltage contact	8	Transformer isolation	5 V DC min. 20 mA min.	200 Ωmax.	100 K Ωmin.	2.0 ms max. or 17 ms, selectable	2.0 ms max. or 17 ms, selectable	10-point terminal block M3.5 screw	18 points/ common
F3XC08-0C							Input sampling time can be specified for 5steps: Always (0μs), 62.5μs, 250μs, 1ms, and 16ms <sup>*3,4</sup> .	Input sampling time can be specified for 5steps: Always (0μs), 62.5μs, 250μs, 1ms, and 16ms <sup>*3,4</sup> .	18-point terminal block M3.5 screw	8 points/ independent common

\*3: The actual response time is obtained by adding 1 ms max. to the specified value.

\*4: If input interrupt is to be used, set the input sampling time to 62.5 μs or more.

Model	Input Type	Number of Points	Isolation Method	Rated Input Voltage	Operating Voltage/Current		Input Frequency	Count-up Output	Output Condition	Output Contact Rating	External Connection
					ON	OFF					
F3XS04-3N	DC voltage	4	Photocoupler isolation	24 V DC	16 V DC min. 7.2 mA min.	6 V DC max. 2.5 mA min.	0 to 20 kHz	4 independent points	Count value= Set value 1 Count value≥ Set value 1 Count value= Set value 2 Count value≥ Set value 2 Count value= \$0 return	Open collector output: 12 to 24 V DC	18-point terminal block M3.5 screw
F3XS04-4N				12 V DC	8.0 V DC min. 6.3 mA min.	3.5 V DC max. 2.4 mA min.					

Model	Output Type	Number of Points	Isolation Method	Rated Load Voltage	Maximum Load Current	Output Response Time		Surge Protector	External Connection	External Power Supply	Number of Points/Common	HOLD/RESET Output When Program Stops <sup>3</sup>		
						OFF→ON	ON→OFF							
F3YD04-7N	Transistor contact	4	Photocoupler isolation	24V DC	2 A/point	5 ms max.	3 ms max.	Zener diode	10-point terminal block M3.5 screw	None	All points independent	When a sequence CPU is used: Initial value: RESET Configurable on module basis <sup>2</sup> . When a BASIC CPU is used: No setup function is enabled; always HOLD. When a OS-free CPU is used: initial value: HOLD Can be set every 8 points <sup>5</sup> .		
F3YA08-2N	TRIAC contact	8		100-240V AC	1 A/point (0-40°C) 0.7 A/point (40-55°C) 3 A/common	1 ms max.	1/2 cycle +1 ms max.	CR absorber varistor						
F3YC08-0C	Relay contact		Mechanical isolation	24V DC 100-240V AC	2 A/point	10 ms max.	10 ms max.	None	18-point terminal block M3.5 screw	All points independent				
F3YC08-0N	Relay contact	2 A/point 8 A/common			10-point terminal block M3.5 screw				8 points/common					
F3YC16-0N	Relay contact	16	Mechanical isolation	24V DC 100-240V AC	2 A/point 8 A/common	10 ms max.	10 ms max.	None	18-point terminal block M3.5 screw	None	8 points/common			
F3YD08-6A	Transistor contact (sink type)	8	Photocoupler isolation	12-24V DC	1 A/point 4 A/common	1 ms max.	1 ms max.	Active clamp	10-point terminal block M3.5 screw	12-24 V DC 10 mA	8 points/common			
F3YD08-6B	Transistor contact (source type)				2 A/point 8 A/common									
F3YD08-7A	Transistor contact (sink type)				0.5 A/point 2 A/common									
F3YD14-5A	Transistor contact (sink type)	14			0.5 A/point 2 A/common	0.1 ms max.	0.1 ms max.	Active clamp	18-point terminal block M3.5 screw	12-24V DC 20mA	8 points/ 6 points/ common			
F3YD14-5B	Transistor contact (source type)													
F3YD32-1H <sup>4</sup>	Transistor contact (sink type)	32			Photocoupler isolation	5V DC	0.1 A/point 0.5 A/common	1 ms max.	1 ms max.	None	One 40-pin connector		12-24 V DC 30 mA	8 points/ common
F3YD32-1P <sup>4</sup>	Transistor contact (sink type)												12-24 V DC 55 mA	
F3YD32-1R <sup>4</sup>	Transistor contact (source type)												12-24 V DC 60 mA	
F3YD32-1T	Transistor contact (TTL output)											5 V DC 60 mA		
F3YD64-1M	Transistor contact (matrix scan)	64			Photocoupler isolation	12-24V DC	0.1 A	16 ms max.	16 ms max.	Zener diode	One 40-pin connector	12-24 V DC 40 mA	8 points/ common	
F3YD64-1P <sup>4</sup>	Transistor contact (sink type)						0.1 A/point 0.4 A/common	1 ms max.	1 ms max.	Active clamp	Two 40-pin connectors	12-24 V DC 95 mA		
F3YD64-1R <sup>4</sup>	Transistor contact (source type)						None	None	12-24 V DC 110 mA					

\*2: Configurable on 16-terminal basis when F3SP22, F3SP28, F3SP38, F3SP53, F3SP58, F3SP59, F3SP66, F3SP67, F3SP71 or F3SP76 is used.

\*3: For details on the operation in the event of a CPU error, see "Severity of Failures and LED Display."

\*4: Provided with output short-circuit protector.

\*5: For the operation when OS-free CPU is used, please refer to "OS-free CPU module status and output module status".

Model	Input Type	Number of Points	Isolation Method	Rated Input Voltage	Rated Input Current	Operating Voltage/Current		Input Response Time		External Connection	Number of Points / Common	HOLD/RESET Output When Program Stops <sup>4</sup>
						ON	OFF	OFF → ON	OFF → ON			
						Output Response Time		Surge Protector	External Power Supply			
OFF → ON	ON → OFF											
F3WD64-3P <sup>5</sup>	DC voltage	32	Photo-Coupler isolation	24 V DC	4.1 mA/point	16 V DC min. 3.2 mA min.	5.8 V DC max. 0.9 mA max.	Input sampling time can be specified for 4steps : Always (0μs), 62.5μs, 250μs and 1ms. <sup>*1,2</sup>	Input sampling time can be specified for 4steps : Always (0μs), 62.5μs, 250μs and 1ms. <sup>*1,2</sup>	One 40-pin connector	8 points/ common	—
	Transistor contact (sink type)	32		24 V DC	0.1 A/point 0.4 A/common	1 ms max.	1 ms max.	Zener diode	24 V DC 55 mA	One 40-pin connector	8 points/ common	When a sequence CPU is used: Initial value: RESET Configurable on module basis <sup>3</sup> .  When a BASIC CPU is used: No setup function is enabled; always HOLD  When a OS-free CPU is used: initial value: HOLD Can be set every 8 points <sup>6</sup>

Model	Input Type	Number of Points	Isolation Method	Rated Input Voltage	Rated Input Current	Operating Voltage/Current		Input Response Time		External Connection	Number of Points / Common	HOLD/RESET Output When Program Stops <sup>4</sup>
						ON	OFF	OFF → ON	OFF → ON			
						Output Response Time		Surge Protector	External Power Supply			
OFF → ON	ON → OFF											
F3WD64-4P <sup>5</sup>	DC voltage	32	Photo-coupler isolation	12 V DC	4.1 mA/point	8 V DC min. 2.6 mA min.	3.4 V DC max. 1 mA max.	Input sampling time can be specified for 4steps : Always (0μs), 62.5μs, 250μs and 1ms. <sup>*1,2</sup>	Input sampling time can be specified for 4steps : Always (0μs), 62.5μs, 250μs and 1ms. <sup>*1,2</sup>	One 40-pin connector	8 points/ common	—
	Transistor contact (sink type)	32		12 V DC	0.1 A/point 0.4 A/common	1 ms max.	1 ms max.	Zener diode	12 V DC 55 mA	One 40-pin connector	8 points/ common	When a sequence CPU is used: Initial value: RESET Configurable on module basis <sup>3</sup> .  When a BASIC CPU is used: No setup function is enabled; always HOLD  When a OS-free CPU is used: initial value: HOLD Can be set every 8 points <sup>6</sup>

Model	Input Type	Number of Points	Isolation Method	Rated Input Voltage	Rated Input Current	Operating Voltage/Current		Input Response Time		External Connection	Number of Points / Common	HOLD/RESET Output When Program Stops <sup>4</sup>
						ON	OFF	OFF → ON	OFF → ON			
						Output Response Time		Surge Protector	External Power Supply			
OFF → ON	ON → OFF											
F3WD64-3E	DC voltage	32	Photo-coupler isolation	24 V DC	4.1 mA/point	16 V DC min. 3.2 mA min.	5.8 V DC max. 0.9 mA max.	Input sampling period can be specified between 0 and 1ms in 4 levels <sup>*1</sup> .	Input sampling period can be specified between 0 and 1ms in 4 levels <sup>*1</sup> .	One 40-pin connector	8 points/ common	initial value: HOLD Can be set every 8 points <sup>6</sup>
	Transistor contact (sink type)	32		24 V DC	0.1 A/point 0.4 A/common	1 ms max.	1 ms max.	Active clamp circuit	24 V DC 55 mA	One 40-pin connector	8 points/ common	

\*1: Can be configured to HOLD or RESET output in the event of a fatal failure when F3SP22, F3SP28, F3SP38, F3SP53, F3SP58, F3SP59, F3SP66, F3SP67, F3SP71 or F3SP76 is used. Indicated values apply to F3SP22, F3SP28, F3SP38, F3SP53, F3SP58, F3SP59, F3SP66, F3SP67, F3SP71 and F3SP76. When other CPU modules are used, the specifications are the same as F3XD□□□□□□. The actual response time can be obtained by adding the following values:  
100 μs (OFF → ON)  
300 μs (ON → OFF)

\*2: If the input interrupt is to be used, set the input sampling period to at least 62.5 μs.

\*3: Configurable on 16-terminal basis when F3SP28, F3SP38, F3SP53, F3SP58, F3SP59, F3SP66, F3SP67, F3SP71 or F3SP76 is used.

\*4: For details on the operation in the event of a CPU error, see "Severity of Failures and LED Display."

\*5: Provided with short-circuit protector.

\*6: For the operation when OS-free CPU is used, please refer to "OS-free CPU module status and output module status".



● Analog I/O

Model	I/O Type	Number of Points	Isolation Method	Input	Output	Resolution	Total Accuracy	Conversion Speed	External Connection	External Power Supply
F3AD04-5V	Analog Input	4	Photocoupler isolation	0 to 5 V DC 1 to 5 V DC -10 to 10 V DC 0 to 10 VDC	-30,000 to 30,000	0 to 5V DC/1 to 5V DC/ 0 to 10V DC : 1.4mV -10 to 10V DC : 5.7mV (12bit A/D)	23±2°C:±0.2% (full scale) 0 to 55°C:±0.5% (full scale)	1 ms × (number of inputs)	18-point terminal block M3.5 screw	—
F3AD08-5V		8		0 to 5 V DC 1 to 5 V DC -10 to 10 V DC 0 to 10 VDC		0 to 5 V DC/1 to 5 V DC/ 0 to 10 V DC : 1.4mV -10 to 10 V DC : 5.7mV (12bit A/D)				
F3AD08-4W		8		0 to 20mA DC 4 to 20mA DC		0 to 20 mA DC/4 to 20 mA DC : 5.6µA (12bit A/D)				
F3AD04-5R	Analog Input Module (High resolution type)	4	Photocoupler isolation	0 to 5 V DC 1 to 5 V DC -10 to 10 V DC 0 to 10 VDC	-30,000 to 30,000	0 to 5 V DC/1 to 5 V DC/ 0 to 10 V DC/-10 to 10 V DC : 0.4mV (16bit A/D)	23±2°C:±0.1% (full scale) 0 to 55°C:±0.2% (full scale)	50µs/100µs/250µs/500µs/ 1ms/16.6ms/20ms/100ms × (number of inputs); selectable on module basis	18-point terminal block M3.5 screw	—
F3AD08-6R		8		0 to 5 V DC 1 to 5 V DC -10 to 10 V DC 0 to 10 V DC 0 to 20mA DC 4 to 20mA DC		0 to 5 V DC/1 to 5 V DC/ -10 to 10 V DC/0 to 10VDC : 0.4mV				
F3AD08-5R		8		0 to 5 V DC 1 to 5 V DC -10 to 10 V DC 0 to 10 V DC		0 to 20mA DC/4 to 20mA DC : 1.6µA (16bit A/D)				
F3AD08-4R		8		0 to 20mA DC 4 to 20mA DC						

Model	I/O Type	Number of Points	Isolation Method	Input	Output	Resolution	Total Accuracy	Conversion Speed	External Connection	External Power Supply
F3DA04-6R	Analog output (High resolution type)	4	Digital isolator	-30,000 to 30,000	-10 to 10 V 0 to 10 V 0 to 5 V 1 to 5 V 4 to 20 mA 0 to 20 mA -20 to 20 mA	Voltage output: ≈0.5 mV (for -10 to 10 V or 0 to 10 V range); ≈0.2 mV (for 0 to 5 V or 1 to 5 V range). Current output: ≈0.5 µA (for 4 to 20 mA range); ≈1 µA (for 0 to 20 mA or -20 to 20 mA range). (16-bit A/D)	Voltage output: ± 0.1% of FS (23±2°C with 10 MΩ load); ± 0.3% of FS (0 to 55°C with 10 MΩ load) Current output: ± 0.2% of FS (23±2°C with 100 Ω load); ± 0.3% of FS (0 to 55°C with 100 Ω load)	2µs + 2µs x (number of inputs)	18-point terminal block M3.5 screws	Rated voltage: 24 V DC Allowable range: 19.2 to 30 V DC Currentconsumption: 200 mA (inrush current: 1A)
F3DA08-5R		8	Digital isolator	-30,000 to 30,000	-10 V to 10 V 0 V to 10 V 1 V to 5 V	Voltage output: 0.5 mV (for -10 to 10 V or 0 to 10 V range); 0.2 mV (for 0 to 5 V or 1 to 5 V range). (16-bit A/D)	Voltage output: ± 0.1% of FS (23±2°C with 10 MΩ load); ± 0.3% of FS (0 to 55°C with 10 MΩ load)	2µs + 2µs x (number of inputs)		Rated voltage: 24 V DC Allowable range: 19.2 to 30 V DC Currentconsumption: 200 mA (inrush current: 1A)

● Temperature

Model	Number of Loops	Isolation Method	Input	Output	Sampling Interval	Control Mode	External Connection	External Power Supply
F3CU04-0S	4	Photocoupler* and transformer isolation	Thermocouple: K, J, T, B, S, R, N, E, L, U, W, Platinel 2	Time-proportional PID output (open collector)	0.2 s	PID, ON/OFF, Heating/cooling	18-point terminal block M3.5 screw	24 V DC 10 mA
F3CU04-1S			RTD: JPt 100, Pt 100	Continuous PID output (4 to 20 mA)				24 V DC 250 mA
F3CX04-0N			DC voltage: 0 to 10 mV, 0 to 100 mV,	—				—

\*: - Input and output lines are photocoupler-isolated from internal circuitry.  
 - Input channels are photocoupler-isolated from each other.  
 - Output channels are not isolated from each other (shared by a common line, which is floating).

● Data Acquisition

Model	I/O Type	Number of Points	Isolation Method	Input	Resolution	Total Accuracy	Input Buffer	Data Acquisition Interval	External Connection
F3HA06-1R	High-speed Data Acquisition	6	Capacitive/ inductive coupling	-10 to 10V DC 0 to 10V DC	-10 to 10 V: Approximately 1/58,000, approximately 0.35 mV 0 to 10 V: Approximately 1/29,000, approximately 0.35 mV	±0.1% of FS (23±2°C), ±0.01% of FS /°C ±0.3% of FS (0 to 55°C)	Maximum: 2M words	Sampling cycle × n, where n is a natural number from 1 to 4,000.	32-pin spring terminal block
F3HA12-1R		12		1 to 5V DC -5 to 5V DC -2.5 to 2.5V DC	1 to 5 V: Approximately 1/23,000, approximately 0.18 mV -5 to 5 V: Approximately 1/58,000, approximately 0.18 mV -2.5 to 2.5 V: Approximately 1/29,000, approximately 0.18 mV (16-bit A/D)				

● Communicators

Model	Type	Transmission Specification					Protocol	External Power Supply
		Access Control Mode	Transmission Speed	Transmission System	Maximum Segment Length	Maximum Number of Nodes		
F3LE01-1T	Ethernet	CSMA/CD system	10 Mbps /100 Mbps	Baseband	100 m	—	TCP/IP, UDP/IP, ICMP, ARP	—
F3LE11-1T			10 Mbps /100 Mbps				TCP/IP, UDP/IP, ICMP, ARP, SMTP, POP3, HTTP 1.0	
F3LE12-1T			10 Mbps /100 Mbps				TCP/IP, UDP/IP, ICMP, ARP	
F3NX01-2N	Ethernet (Autonomous Distribution)	CSMA/CD system	10 Mbps /100 Mbps	Baseband	100 m	—	UDP/IP, ICMP, ARP	—
F3LN01-0N	EtherNet/IP	CSMA/CD system	10 Mbps /100 Mbps	Baseband	100 m	128 nodes	TCP/IP,UDP/IP, ICMP, ARP,CIP	—
F3LX02-2N	FL-net (OPCN-2) Ver2.00	CSMA/CD system	10 Mbps /100 Mbps	Baseband	100 m	254 nodes	UDP/IP, ICMP, ARP	—

Model	Type	Number of I/O Points	Maximum Message Length	Speed	Transmission Distance				Media	Connection Configuration	Number of Nodes	Network Power Source
					Maximum Trunk Line Cable Length		Branch Line Length					
					Only thick cables used	Only thin cables use	Maximum Length	Total Length				
F3LD01-0N	Device Net	Input: 8000 Output: 8000	Send: 84 bytes Receive: 88 bytes (service data)	125Kbps	500 m	100 m	6 m	156 m	5 dedicated cables Signal: 2 lines Shielded: 1 line Power source: 2 lines	Multidrop, T-branch	64 (including master)	Voltage: 24 V DC Current consumption: 40 mA max. (supplied via connector)
				250Kbps	250 m			78 m				
				500Kbps	100 m			39 m				

Model	Type	Speed	Transmission Distance				Media	Connection Configuration	Network Power Source
			Maximum Trunk Line Cable Length		Branch Line Length				
			Only thick cables used	Only thin cables use	Maximum Length	Total Length			
F3LD21-0N	CAN2.0B	125Kbps	500 m	100 m	6 m	156 m	5 dedicated cables Signal: 2 lines Shielded: 1 line Power source: 2 lines	Multidrop, T-branch	Voltage: 24 V DC Current consumption: 40 mA max. (supplied via connector)
		250Kbps	250 m			78 m			
		500Kbps	100 m			39 m			
		1Mbps	25m			25m			

Model	Type	Number of Ports	Insulation	Communication Mode	Transmission Speed	Synchronization	Maximum Transmission Distance	External Connection
F3LC31-2F	Modbus (RS-422A/RS-485)	1	Yes	Half-duplex	115.2Kbps max.	Start-stop synchronization	1200m	6-point terminal block M3.5 screw

Model	Type	Interface	Number of Ports	Transmission System	Connection Configuration	Number of Devices	Handshake System
F3GB01-0N	GP-IB	ANSI/IEEE standard 488 compliant 24-pin receptacle connector (IEEE-488)	1	8-bit parallel, half-duplex	Star, multidrop	15 units max.	3-wire handshaking

Model	Type	Number of Ports	Insulation	Communication Mode	Transmission Speed	Synchronization	Maximum Transmission Distance	External Connection
F3LC11-1F	Personal computer link (RS-232-C)	1	No	Half-duplex	115.2Kbps max.	Start-stop synchronization	15 m	Dsub 9-pin connector
F3LC12-1F	Personal computer link (RS-232-C)	2	No		115.2Kbps max.		1200 m	
F3LC11-2F	Personal computer link (RS-422-A/RS-485)	1	Yes		115.2Kbps max.		15 m	Dsub 9-pin connectors
F3RZ81-0F	Ladder communication*1 (RS-232-C)	1	No	Full-duplex, Half-duplex	115.2Kbps max.	Start-stop synchronization	15 m	Two Dsub 9-pin connectors
F3RZ82-0F	Ladder communication*1 (RS-232-C)	2	No		115.2Kbps max.		1200m	6-point terminal block M3.5 screw
F3RZ91-0F	Ladder communication*1 (RS-422-A/RS-485)	1	Yes		115.2Kbps max.		1200 m	6-point terminal block M3.5 screw
F3LC51-2N	UT link (RS-422-A/RS-485)	1	Yes	Half-duplex	38400 bps max.	Start-stop synchronization	1200 m	6-point terminal block M3.5 screw
F3LP32-0N	FA link H2	1	Yes	Token-bus system	1.25Mbps max.	Frame synchronization	1 km	European-type terminal block, Tbranch connector

\*1: Compatible with sequence CPUs.

● Remote I/O

Model	Type	Number of Ports	Insulation	Communication Mode	Transmission Speed	Synchronization	Maximum Transmission Distance	External Connection
F3LH01-1N	YHLS	1	Yes	Full-duplex, Half-duplex	12Mbps max.	Bit synchronization	300 m	European-type terminal block
F3LH02-1N	YHLS	2	Yes					European-type terminal block
F3LR01-0N	Fiber-optic FA-bus	1	Yes	Both half-duplex bit serial transmission and cyclic scan are used.	10 Mbps /100 Mbps	Bit synchronization	200 m	Optical connector
F3LR02-0N	Fiber-optic FA-bus type 2	2	Yes				1.4 km	Optical connector
F3LR02-1W	FA-bus type 2	2	Yes				80 m	European-type terminal block

● Counter/ positioning

Model	Input Type	Number of Points	Isolation Method	Input Signal				Input Frequency	Count-up Output	Output Condition	Output Contact Rating	External Connection
				Signal	Rated Input Voltage	Operating Voltage/Current						
						ON	OFF					
F3XP01-0H	DC voltage	1	Photocoupler isolation	A,B, PST	5V DC	3.5 V min. 10 mA min	1.5 V max. 2 mA max.	0 to 100 kpps	2 points for each input point	Counter value = Set value	Transistor output: 5 to 24 V DC	One 40-pin connector
					12V DC	8 V min. 10 mA min	2.4 V max. 2 mA max.					
					24V DC	16 V min. 10 mA min	4.8 V max. 2 mA max.					
				EN	5V DC	3.5 V min. 3.2 mA min	1.5 V max. 0.9 mA max.					
					12V DC	8 V min. 3.2 mA min.	2.4 V max. 0.9 mA max.					
					24V DC	16 V min. 3.2 mA min	4.8 V max. 0.9 mA max.					
F3XP02-0H	DC voltage	2	Photocoupler isolation	A,B, PST	5V DC	3.5 V min. 10 mA min	1.5 V max. 2 mA max.	0 to 100 kpps	2 points for each input point	Counter value = Set value	Transistor output: 5 to 24 V DC	Two 40-pin connectors
					12V DC	8 V min. 10 mA min.	2.4 V max. 2 mA max.					
					24V DC	16 V min. 10 mA min	4.8 V max. 2 mA max.					
				EN	5V DC	3.5 V min. 3.2 mA min	1.5 V max. 0.9 mA max.					
					12V DC	8 V min. 3.2 mA min	2.4 V max. 0.9 mA max.					
					24V DC	16 V min. 3.2 mA min	4.8 V max. 0.9 mA max.					

Model	Type	Number Of Axes	Control Mode	Positioning Command Range	Speed Command Range	Acceleration/ Deceleration	Interpolation Function	Data Backup	External Connection	External Power Supply	
F3NC32-0N	With pulse output	2	Position control, speed control	-2,147,483,648 to 2,147,483,648	0.1 to 5Mpps (by servo otor)	Automatic trapezoidal ACC/DEC (starting speed programmable)	1-axis movement, 2-axis linear Interpolation, 2-axis arc Interpolation	Carried out by flash memory or CPU module	One 48-pin connector	24V DC 80mA	
F3NC34-0N		4			0.1 to 1 Mpps (by pulse otor)	Automatic S-shaped ACC/DEC (starting speed fixed))	1-axis movement, 2/3/4-axis linear Interpolation, 2-axis arc Interpolation, 3/4-axis helical interpolation		Two 48-pin connectors	24V DC 120mA	
F3NC51-0N	With analog voltage output (absolute encoder compatible)	1	Position control, speed control	-134,217,728 to 134,217,727	0.1 to 2 Mpps	Automatic trapezoidal ACC/DEC, 2-segment, S-shaped (3-segment)	Multiaxial linear interpolation, 2-axis arc interpolation as specified by CPU instructions	Carried out by CPU module	One 40-pin connector	24 V DC 10 mA	
F3NC52-0N		2							Two 40-pin connectors		
F3NC96-0N	With MECHATROLINK-II interface	15	Position control, speed control, torque control	-2,147,483,648 to 2,147,483,647 <sup>*1</sup>	1 to 2,147,483,647 <sup>*1</sup>	Automatic trapezoidal ACC/DEC <sup>*1</sup>	Linear interpolation as specified by CPU instructions, axis movement as specified by MECHATROLINK-II commands	Carried out by CPU module	One MECHATROLINK-II communication port	—	
F3NC97-0N	With MECHATROLINK-III interface	15	Position control, speed control, torque control	-2,147,483,648 to 2,147,483,647 <sup>*1</sup>	1 to 2,147,483,647 <sup>*1</sup>	Automatic trapezoidal ACC/DEC <sup>*1</sup>	Linear interpolation as specified by CPU instructions, axis movement as specified by MECHATROLINK-III commands	Carried out by CPU module	Two MECHATROLINK-III communication ports	—	
F3YP22-0P	With multi-channel pulse output	2	Position control, speed control	-2,147,483,648 to 2,147,483,647	1 to 7,996,000 pps (by servo otor)	Automatic trapezoidal ACC/DEC (starting speed programmable) Automatic S-shape ACC/DEC (starting speed fixed)	—	Carried out by flash memory or CPU module	One 48-pin Connector One 14-pin connector	24 V DC 70mA	
F3YP24-0P		4			1 to 1999,000 pps (by pulse otor)				—	One 48-pin Connector One 14-pin connector	24 V DC 110mA
F3YP28-0P		8			—				—	Two 48-pin Connector One 14-pin connector	24 V DC 200mA

\*1: Depends on the connected external instruments and the supported MECHATROLINK commands.

■ Terminal Block Unit

Model	Number of Points	Rated Voltage	Operating Voltage Range	Maximum Current	Cable	Terminal Block Screw	Mounting Screw
TA40-0N	40	5-24 V DC	4.5 to 26.4 V DC	0.5 A DC/point	0.08 to 0.26 mm <sup>2</sup>	M2 (minus thread)	M2.6 (minus thread)
TA50-0N	40	5-24 V DC	4.5 to 26.4 V DC	0.5 A DC/point	2 mm <sup>2</sup> max.	M3.5	M4 (2 points)
TA50-2N	40	5-24 V DC	4.5 to 26.4 V DC	0.5 A DC/point	1.25 mm <sup>2</sup> max.	M3	M4 (2 points)

■ YHLS Slave Units (TAH Series)

● Input Units

Model	Input Type	Number of Points	Isolation Method	Rated Input Voltage	Rated Input Current	Operating Voltage/Current		Input Response Time		External Connection	Number of Points /Common	External Power Supply
						ON	OFF	OFF→ON	ON→OFF			
TAHXD16-3PEM	DC voltage (+ common)	16	Photo-coupler isolation	24 V DC	4.1 mA/point	16.0 VDC min. 3.2 mA min.	5.8 V DC max 0.9 mA min.	1.0 ms max.	1.0 ms max.	MIL, 26 pins	16 points/ common	20.4-26.4V DC 100 mA
TAHXD16-3NEM	DC voltage (- common)											

● Output Units

Model	Output Type	Number of Points	Isolation Method	Rated Load Voltage	Maximum Load Current	Output Response Time		HOLD/RESET Output on YHLS Communication Error or when Program Stops	External Connection	Number of Points /Common	External Power Supply
						OFF→ON	ON→OFF				
TAHYD16-3EAM	Transistor contact (sink type)	16	Photo-coupler isolation	24 V DC	0.1 A/point	1 ms max.	1 ms max.	Configurable globally by DIP switch HLD:HOLD R:RESET	MIL, 26 pins	16 points/ common	20.4-26.4V DC 100 mA
TAHYD16-3EBM	Transistor contact (source type)										

● I/O Units

Model	Input Type	Number of Points	Isolation Method	Rated Input Voltage	Rated Input Current	Operating Voltage/Current		Input Response Time		External Connection	Number of Points /Common	External Power Supply
						ON	OFF	OFF→ON	ON→OFF			
TAHWD32-3PAM	DC voltage (+ common)	16	Photo-coupler isolation	24 V DC	4.1 mA/point	16.0 VDC min. 3.2 mA min.	5.8 VDC max. 0.9 mA min.	1.0 ms max.	1.0 ms max.	MIL, 26 pins	16 points/ common	20.4-26.4 V DC 100 mA
	Output Type											
	Transistor contact (sink type)	16	Photo-coupler isolation	24 V DC	0.1 A/point	1 ms max.	1 ms max.	Configurable globally by DIP switch HLD:HOLD R:RESET	MIL, 26 pins	16 points/ common		

Model	Input Type	Number of Points	Isolation Method	Rated Input Voltage	Rated Input Current	Operating Voltage/Current		Input Response Time		External Connection	Number of Points /Common	External Power Supply
						ON	OFF	OFF→ON	ON→OFF			
TAHWD32-3NBM	DC voltage (- common)	16	Photo-coupler isolation	24 V DC	4.1 mA/point	16.0 VDC min. 3.2 mA min.	5.8 VDC max. 0.9 mA min.	1.0 ms max.	1.0 ms max.	MIL, 26 pins	16 points/ common	20.4-26.4 V DC 100 mA
	Output Type											
	Transistor contact (source type)	16	Photo-coupler isolation	24 V DC	0.1 A/point	1 ms max.	1 ms max.	Configurable globally by DIP switch HLD:HOLD R:RESET	MIL, 26 pins	16 points/ common		

■ Standard Accessories

Module name	Model	Accessory	Quantity
Base module	F3BU04-0N	Connector dust cover	2
	F3BU06-0N	Connector dust cover	2
	F3BU05-0D	Connector dust cover	2
	F3BU09-0N	Connector dust cover	4
	F3BU13-0N	Connector dust cover	4
	F3BU16-0N	Connector dust cover	4

■ Spare Parts

Item	Part No.	Applicable Module
Terminal (10-point terminal block)	A1474JT	F3XH04, F3XA08, F3XC08-0N, F3XD08, F3YD04, F3YA08, F3YC08, F3YD08, F3AD04-0N, F3AD04-0R, F3AD04-0V, F3DA02 <sup>*2</sup> .
Terminal (10-point terminal block) cover	T9113PF	
Terminal (18-point terminal block)	T9112ZU	F3CU04, F3CX04
Terminal (18-point terminal block) cover	A1496JT	F3YC16, F3XA16, F3XC08-0C, F3XD16, F3YD14, F3CR04 <sup>*2</sup> , F3CV04 <sup>*2</sup> , F3CU04, F3CX04, F3AD04-5R, F3AD04-5V, F3AD08, F3DA04, F3DA08, F3XS04, F3HA08
Terminal (18-point terminal block) cover	T9113PG	
Soldered-type connector (40-pin plug)	A1451JD <sup>*1</sup>	F3XD32, F3XD64, F3WD64, F3XP01, F3XP02, F3YD32, F3YD64, F3NC11 <sup>*2</sup> , F3NC12 <sup>*2</sup> , F3NC51, F3NC52
Connector (40-pin plug) cover	A1452JD <sup>*1</sup>	
Soldered-type connector (48-pin plug)	A1612JD <sup>*1</sup>	F3YP04 <sup>*2</sup> , F3YP08 <sup>*2</sup> , F3YP14 <sup>*2</sup> , F3YP18 <sup>*2</sup> , F3YP22, F3YP24, F3YP28, F3NC32, F3NC34
Connector (48-pin plug) cover	A1613JD <sup>*1</sup>	
Connector dust cover (4pcs/bag)	T9031AS	F3BU04, F3BU06, F3BU05, F3BU09, F3BU13, F3BU16
Rail mount kit (1 set)	T9031AP <sup>*1</sup>	F3BU04, F3BU05, F3BU06
Rail mount kit (2 set)	T9031AQ <sup>*1</sup>	F3BU09, F3BU13

\*1: Not supplied with the product.

\*2: Discontinued Module

## Restrictions on Module Installation

### ■ Restrictions on Module Location

- The CPU module installed in slot 1 serves as the main CPU module.
- The CPU modules installed in slots 2 to 4 serve as add-on CPU modules.
- I/O modules may be installed in slots 2 to 4. Neither add-on sequence CPU modules nor add-on BASIC CPU modules can be installed in any slots whose slot number is greater than that of the installed I/O modules.
- When two or more CPU modules are to be used, no I/O modules can be installed between CPU modules.

Slot No.	1	2	3	4	5	6	Slot No.	1	2	3	4	5	6	Slot No.	1	2	3	4	5	6	
	Power supply	Main CPU module	Add-on CPU module	I/O module	I/O module	.	.	Power supply	Main CPU module	I/O module	Add-on CPU module	I/O module	.	.	Power supply	Main CPU module	Free	Add-on CPU module	I/O module	.	.
	OK							NG							OK						

### ■ Restrictions on CPU Module Installation

- A maximum of four CPU modules can be installed in slots 1 to 4 of the main unit.

Model	Maximum Qty. <sup>*1</sup>	Add-on CPU Module																			
		F3RP70-2L	F3SP22-0S	F3SP28-3S	F3SP38-6S	F3SP53-4S	F3SP58-6S	F3SP6□-□S	F3SP7□-□S	F3BP20-0N	F3BP30-0N										
Main CPU Module																					
F3RP70-2L	4	✓	✓	×	×	×	×	×	×	✓	×	×	×	×	×	×	×	×	×	×	×
F3SP22-0S	4	✓	✓	✓	✓	✓	✓	✓	✓	✓	✓	✓	✓	✓	✓	✓	✓	✓	✓	✓	✓
F3SP28-3S	4	×	✓	✓	✓	✓	✓	✓	✓	✓	✓	✓	✓	✓	✓	✓	✓	✓	✓	✓	✓
F3SP38-6S	4	×	✓	✓	✓	✓	✓	✓	✓	✓	✓	✓	✓	✓	✓	✓	✓	✓	✓	✓	✓
F3SP53-4S	4	×	✓	✓	✓	✓	✓	✓	✓	✓	✓	✓	✓	✓	✓	✓	✓	✓	✓	✓	✓
F3SP58-6S	4	×	✓	✓	✓	✓	✓	✓	✓	✓	✓	✓	✓	✓	✓	✓	✓	✓	✓	✓	✓
F3SP6□-□S	4	×	✓	✓	✓	✓	✓	✓	✓	✓	✓	✓	✓	✓	✓	✓	✓	✓	✓	✓	✓
F3SP7□-□S	4	✓	✓	✓	✓	✓	✓	✓	✓	✓	✓	✓	✓	✓	✓	✓	✓	✓	✓ <sup>*2</sup>	✓ <sup>*2</sup>	✓ <sup>*2</sup>
F3BP20-0N	1	×	✓	✓	✓	✓	✓	✓	✓	✓	✓	✓	✓	×	×	×	×	×	×	×	×
F3BP30-0N	1	×	✓	✓	✓	✓	✓	✓	✓	✓	✓	✓	✓	×	×	×	×	×	×	×	×

\*1: Indicates the maximum number of modules that can be used in total including the main CPU module when CPU modules with the same model name as the main CPU module are used as add-on CPU modules.

\*2: A maximum of two modules can be installed in this combination.

\*3: The combination of F3SP7□-□N + F3SP7□-□N + F3SP21 (25, 35/ F3BP20, 30) is not possible.  
 The combination of F3SP7□-□N + F3SP7□-□S + F3SP21 (25, 35/ F3BP20, 30) is not possible.  
 The combination of F3SP7□-□S + F3SP7□-□S + F3SP21 (25, 35/ F3BP20, 30) is possible.  
 The combination of F3SP7□-□N + F3SP7□-□S is possible.

**■ Restrictions on I/O Module Installation**

- The table below summarizes the number of modules that a CPU module can gain direct access to and the number of modules that can be installed. The number of modules that can be installed here refers to I/O modules of the same type.
  - A circle denotes an I/O module that has no restriction as to the number of modules that can be installed.
  - An "x" denotes an I/O module to which the associated CPU module can gain no direct access.
  - A number indicates the number of I/O modules of the same type that can be installed.
- The restrictions to which I/O modules are subject to include those on the number of a particular type that can be installed and those on the total number of I/O modules of all types that can be installed in the entire system.
- For the end of sale modules of FA-M3, please refer to TI 34M06Z40-01E

**Modules That Each CPU Can Access Directly and the Maximum Number of Them That Can Be Installed (1/2)**

Module Name	Model	Sequence CPU			OS-free CPU
		F3SP22-0S	F3SP71-4S	F3SP76-7S	
Memory card module	F3EM01-0N	6 <sup>1</sup>	6 <sup>1</sup>	6 <sup>1</sup>	x
Digital Input module	F3XA□□-□N	✓	✓	✓	✓
	F3XH04-3N	16	16	16	16 <sup>2</sup>
	F3XC08-0□	✓	✓	✓	✓
	F3XD08-6F	✓	✓	✓	✓
	F3XD08-6N	✓	✓	✓	✓
	F3XD16-□F	✓	✓	✓	✓
	F3XD16-3H	✓	✓	✓	✓
	F3XD32-□F	✓	✓	✓	✓
	F3XD16-□N	✓	✓	✓	✓
	F3XD32-□N	✓	✓	✓	✓
	F3XD64-□□	64	64	✓	✓
Pulse input module	F3XS04-□N	36	36	36	36
Digital Output module	F3YA08-2N	✓	✓	✓	✓
	F3YC08-0C	✓	✓	✓	✓
	F3YC08-0N	✓	✓	✓	✓
	F3YC16-0N	✓	✓	✓	✓
	F3YD04-7N	✓	✓	✓	✓
	F3YD08-□□	✓	✓	✓	✓
	F3YD14-5□	✓	✓	✓	✓
	F3YD32-1□	✓	✓	✓	✓
	F3YD64-1□	64	64	✓	✓
Input/Output module	F3WD64-□□	64	64	✓	✓
Analog input module	F3AD04-□□	36	36	36	36
	F3AD08-□□	36	36	36	36
Analog output module	F3DA02-0N	36	36	36	36
	F3DA04-1N	36	36	36	36
	F3DA08-5N	36	36	36	36
Temperature control and monitoring module	F3CT04-□N	28	28	28	28
	F3CR04-□N	28	28	28	28
PID control module	F3CV04-1N	28	28	28	28
Temperature control and PID module	F3CU04-□□	36	36	36	36
Temperature monitoring module	F3CX04-0N	36	36	36	36
High-speed data acquisition module	F3HA08-0N	8	8	8	8
	F3HA□□-1R	8	8	8	8
ASi Master module	F3LA01-0N	36	36	36	36
PROFIBUS-DP interface module	F3LB01-0N	16	16	16	16
Ethernet interface module	F3LE01-□T	6 <sup>1</sup>	6 <sup>1</sup>	6 <sup>1</sup>	6 <sup>118</sup>
	F3LE01-5T	6 <sup>1</sup>	6 <sup>1</sup>	6 <sup>1</sup>	6 <sup>118</sup>
	F3LE11-□T	6 <sup>1</sup>	6 <sup>1</sup>	6 <sup>1</sup>	6 <sup>118</sup>
	F3LE12-□T	6 <sup>1</sup>	6 <sup>1</sup>	6 <sup>1</sup>	6 <sup>118</sup>
NX interface module	F3NX01-□N	6 <sup>1</sup>	6 <sup>1</sup>	6 <sup>1</sup>	x
EtherNet/IP interface module	F3LN01-0N	1 <sup>10</sup>	1 <sup>10</sup>	2 <sup>10</sup>	x
FL-net (OPCN-2) interface module	F3LX02-1N	1 <sup>10</sup>	1 <sup>10</sup>	2 <sup>10</sup>	x
	F3LX02-2N	1 <sup>10</sup>	1 <sup>10</sup>	2 <sup>10</sup>	x
DeviceNet interface module	F3LD01-0N	16	16	16	16
CAN2.0B interface module	F3LD21-0N	8	8	8	8
Modbus interface module	F3LC31-2F	6 <sup>1</sup>	6 <sup>1</sup>	6 <sup>1</sup>	6 <sup>1</sup>

**Modules That Each CPU Can Access Directly and the Maximum Number of Them That Can Be Installed (2/2)**

Module Name	Model	Sequence CPU				OS-free-CPU		
		F3SP22-0S	F3SP71-4S	F3SP76-7S	F3RP70-2L			
GP-IB communication module <sup>5</sup>	F3GB01-0N	8	6 <sup>*1</sup>	8	6 <sup>*1</sup>	8	x	
Personal computer link module	F3LC11-1F	6 <sup>*1</sup>	6 <sup>*1</sup>	6 <sup>*1</sup>	6 <sup>*1</sup>			
	F3LC11-1N							
	F3LC11-2□							
	F3LC12-1F							
Ladder communication module	F3RZ81-0N	36	36	36	36			
	F3RZ81-0F	28	28	28	36			
	F3RZ82-0F	28	28	28	36			
	F3RZ91-0□	36	36	36	36			
RS-232-C communication module	F3RS22-0N	x	x	x	x			
RS-422-A communication module	F3RS41-0N	x	x	x	x			
UT link module	F3LC51-2N	4	4	4	4		x	
FA link H module	F3LP02-0N						x	
Fiber-optic FA link H module	F3LP12-0N	8 <sup>*3*7*10</sup>	8 <sup>*3*7*10</sup>	8 <sup>*3*7*10</sup>			x	
FA link H2 module	F3LP32-0N						x	
YHLS master module	F3LH0□-0N	15	15	15	15			
	F3LH01-1N	28	28	28	28			
	F3LH02-1N	28	28	28	28			
Fiber-optic FA-bus module	F3LR01-0N	7 <sup>*4</sup>	7 <sup>*4</sup>	7 <sup>*4</sup>	7 <sup>*4</sup>		7 <sup>*4</sup>	
Fiber-optic FA-bus type 2 module	F3LR02-0N						7 <sup>*4</sup>	
FA-bus type 2 module	F3LR02-1W	7 <sup>*4</sup>	7 <sup>*4</sup>	7 <sup>*4</sup>	7 <sup>*4</sup>		7 <sup>*4</sup>	
High-speed counter module	F3XP01-0H	64	64	✓	✓		✓	
	F3XP02-0H	64	64	✓	✓		✓	
Positioning module	(with multi-channel pulse output)	F3YP04-0N	36	36	36	36		
		F3YP08-0N	36	36	36	36		
		F3YP14-0N	36	36	36	36		
		F3YP18-0N	36	36	36	36		
		F3YP22-0P	16	16	16	16		
		F3YP24-0P	16	16	16	16		
		F3YP28-0P	16	16	16	16		
	(advanced model with pulse output)	F3NC11-0N	36	36	36	36		
		F3NC12-0N	36	36	36	36		
	(with pulse output)	F3NC32-0N	16	16	16	36		
		F3NC34-0N	16	16	16	36		
	(with analog voltage output)	F3NC51-0N	36	36	36	36		
		F3NC52-0N	36	36	36	36		
	(MECHATROLIN K-II)	F3NC96-0N	8	8	8	8		
(MECHATROLINK-III)	F3NC97-0N	8	8	8	8			

Modules with shaded module names and models must be installed in main units.

- \*1: Each number denotes the largest combined number of personal computer link modules, Ethernet interface modules, GP-IB communication modules (when in slave mode), FL-net interface modules, EtherNet/IP interface modules, Modbus interface module and memory card modules that can be installed. If two or more CPU modules having different maximum limits are installed, the smallest limit applies.
- \*2: The pulse-capture feature is disabled.
- \*3: Each number denotes the largest combined number of FA link H2 modules and fiber-optic FA link H modules that can be installed. If two or more CPU modules having different maximum limits are installed, the smallest limit applies.
- \*4: Each number denotes the largest combined number of fiber-optic FA-bus, fiber-optic FA-bus type 2 and FA-bus type 2 modules that can be installed in a main unit. If two or more CPU modules having different maximum limits are installed, the smallest limit applies. If subunits are grouped using fiber-optic FA-bus type 2 modules, the maximum limit may be increased depending on the grouping pattern. For more information, see the Fiber-optic FA-bus Module and Fiber-optic FA-bus Type 2 Module, FA-bus Type 2 Module (IM 34M06H45-01E).
- \*5: The maximum number of each module that can be installed depends on the operating mode. The left number and right number in each cell apply when the module is in master mode and slave mode respectively.
- \*7: Up to 7 modules can be installed if used with FL-net (OPCN-2) interface module or EtherNet/IP interface module, provided link device capacities are not exceeded.
- \*8: Only higher-level link function (personal computer link command) is available.
- \*10: Each number denotes the largest combined number of EtherNet/IP interface modules, FL-net (OPCN-2) interface module, FA link H modules, FA link H2 modules and fiber-optic FA link H modules that can be installed.



## Current Consumption

Make sure that the total current consumption (at 5 V DC) in the installed modules does not exceed the 5 V power capacity of the power supply module used. Prepare an appropriate external power supply according to the specifications of the modules used.

### ■ Base Modules

Module Name	Model	Maximum Current Consumption (mA) at 5 V DC	External Power Supply	
			Voltage (V DC)	Current (mA)
Base module	F3BU04-0N	50	—	—
	F3BU06-0N	50	—	—
	F3BU05-0D	50	—	—
	F3BU09-0N	50	—	—
	F3BU13-0N	50	—	—
	F3BU16-0N	50	—	—

### ■ Power Supply Modules

Model Name	Model	Internal 5 V Source (mA)	Power Supplied to External Devices (mA)
Power supply module	F3PU10-0S	2000	No
	F3PU16-0S	2000	No
	F3PU20-0S	4300	No
	F3PU26-0S	4300	No
	F3PU30-0S	6000	No
	F3PU36-0S	6000	No

### ■ CPU Modules

Module Name	Model	Maximum Current Consumption (mA) at 5 V DC	External Power Supply	
			Voltage (V DC)	Current (mA)
OS-free CPU module	F3RP70-2L	1200	—	—
Sequence CPU module	F3SP22-0S	450	—	—
	F3SP71-4S	460	—	—
	F3SP76-7S	460	—	—

■ I/O Modules

Module Name	Model	Maximum Current Consumption (mA) at 5 V DC	External Power Supply	
			Voltage (V DC)	Current (mA)
High-speed input module	F3XH04-3N	30	—	—
AC input module	F3XA08-1N	40	—	—
	F3XA08-2N	40	—	—
DC input module	F3XA16-1N	65	—	—
	F3XD08-6F	40	—	—
	F3XD16-3F	65	—	—
	F3XD16-4F	65	—	—
	F3XD16-3H	65	—	—
	F3XD32-3F	75	—	—
	F3XD32-4F	75	—	—
	F3XD32-5F	75	—	—
	F3XD64-3F	100	—	—
	F3XD64-4F	100	—	—
No-voltage contact input module	F3XD64-6M	110	12-24	70
	F3XC08-0N	75	—	—
Pulse input module	F3XC08-0C	75	—	—
	F3XS04-3N	230	—	—
TRIAC output module	F3XS04-4N	230	—	—
	F3YA08-2N	130	—	—
Relay output module	F3YC08-0C	205	—	—
	F3YC08-0N	205	—	—
	F3YC16-0N	380	—	—
Transistor output module	F3YD04-7N	85	—	—
	F3YD08-6A	60	12-24	10
	F3YD08-6B	60	12-24	10
	F3YD08-7A	80	12-24	10
	F3YD14-5A	120	12-24	20
	F3YD14-5B	120	12-24	20
	F3YD32-1H	165	12-24	30
	F3YD32-1P	160	12-24	55
	F3YD32-1R	170	12-24	60
	F3YD32-1T	210	5	60
	F3YD64-1M	125	12-24	40
Input/Output module	F3YD64-1P	275	12-24	95
	F3YD64-1R	275	12-24	110
	F3WD64-3P	170	24	55
	F3WD64-4P	170	12	55
Analog input module	F3WD64-3E	170	24	55
	F3AD04-5R	210	—	—
	F3AD04-5V	210	—	—
	F3AD08-5V	210	—	—
	F3AD08-4W	210	—	—
	F3AD08-4R	210	—	—
	F3AD08-5R	210	—	—
Analog output module	F3AD08-6R	210	—	—
	F3DA04-6R	60	24	200
Temperature control and PID module	F3DA08-5R	60	24	200
	F3CU04-0S	460	24	10
Temperature monitoring module	F3CU04-1S	470	24	250
	F3CX04-0N	440	—	—
High-speed data acquisition module	F3HA06-1R	420	—	—
	F3HA12-1R	570	—	—
Ethernet interface module	F3LE01-1T	330	—	—
	F3LE11-1T	330	—	—
	F3LE12-1T	330	—	—
NX interface module	F3NX01-2N	330	—	—
EtherNet/IP interface module	F3LN01-0N	330	—	—
FL-net (OPCN-2) interface module	F3LX02-2N	330	—	—
DeviceNet interface module	F3LD01-0N	200	11-25	40
CAN2.0B interface module	F3LD21-0N	200	11-25	40
Modbus interface module	F3LC31-2F	290	—	—
GP-IB communications module	F3GB01-0N	250	—	—
	F3LC11-1F	320	—	—
Personal computer link module	F3LC11-2F	350	—	—
	F3LC12-1F	350	—	—
	F3RZ81-0F	320	—	—
Ladder communications module	F3RZ82-0F	350	—	—
	F3RZ91-0F	350	—	—
	F3LC51-2N	290	—	—
UT link module	F3LP32-0N	220	—	—
YHLS master module	F3LH01-1N	360	—	—
	F3LH02-1N	480	—	—
	F3LH02-0N	440	—	—
Fiber-optic FA-bus module	F3LR01-0N	220	—	—
Fiber-optic FA-bus type 2 module	F3LR02-0N	460	—	—
FA-bus type 2 module	F3LR02-1W	320	—	—

Module Name	Model	Maximum Current Consumption (mA) at 5 V DC	External Power Supply	
			Voltage (V DC)	Current (mA)
High-speed counter module	F3XP01-0H	100	—	—
	F3XP02-0H	150	—	—
Positioning module (with pulse output)	F3NC32-0N	450	24	80
	F3NC34-0N	540	24	120
Positioning module (with analog voltage output)	F3NC51-0N	390	24	10
	F3NC52-0N	400	24	10
Positioning module (with MECHATROLINK-II Interface)	F3NC96-0N	570	—	—
Positioning module (with MECHATROLINK-III Interface)	F3NC97-0N	530	—	—
Positioning module (with multi-channel pulse output)	F3YP22-0P	210	24	70
	F3YP24-0P	240	24	110
	F3YP28-0P	280	24	200

## Severity of Failures and LED Display

### ■ Severity of Failures and LED Display (For F3SP22 and F3SP7□ CPU modules)

Error Severity	LED Display	Description	Error Item*3	FAIL-signal Contact Output		Status of Output Module	
				Between FAIL 1 and COM	Between FAIL 2 and COM	Output modules with 32 or fewer outputs, F3YD64-1F, F3YD64-1P, F3YD64-1R, F3WD64-□F and F3WD64-□P	F3YD64-1A, F3YD64-1M, F3WD64-□N, and Y□□□□□*2
Major	RDY (green) off	The core hardware is disabled.	- Hardware failure - SPU error*4 - Memory error*4	Shorted	Open	Initial value: RESET Configurable on 16-point basis.	All settings are invalid; always HOLD
Moderate	ERR (red) lit	The user program cannot be started or run any further.	- Startup error - Boot mode error - SPU error*4 - Memory error*4 - Invalid instruction found - Program error - ROM pack error - Power Failure While Writing to a Flash ROM - /Flash memory error - Battery error/Memory check error - Subroutine error*1 - Interrupt error*1 - Instruction error*1, Macro instruction error*1 - I/O comparison error*1 - I/O module error*1 - Scan timeout*1 - Sensor CB scan timeout*1 - Subunit communication error*1	Shorted	Open	Initial value: RESET Configurable on 16-terminal basis.	Initial value: RESET Configurable on 16-terminal basis.
Minor	ALM (yellow) lit	The user program can still run in spite of a failure.	- Momentary power failure - Inter-CPU communication error - Subunit transmitter switching has occurred - FA link error	Open	Shorted	Operation continues.	Operation continues.

\*1: Can be configured as minor failure or moderate failure.  
 \*2: Output relays (Y□□□□□) of advanced modules.  
 \*3: It depends on model. Please refer to the user's manual of each model.  
 \*4: Depending on the content, it may cause major failure and moderate failure.

### ■ OS-free CPU module status and output module status

On each status of CPU, FAIL contact of output and power modules operate like below.

Status of CPU Module	Status of Output Module	FAIL-signal Contact Output	
		Between FAIL 1 and COM	Between FAIL 2 and COM
Power OFF	—	shorted	open
Operating	—	open	shorted
Operating and Watchdog time out*1	Configurable (“HOLD” or “RESET”) with setting of MODE registers*2	shorted	open
Operating and executing failure output using RAS API	Configurable (“HOLD” or “RESET”) with setting of MODE registers*2	shorted	open

\*1 : These features are included in RAS libraries, and can be called from user application optionally.  
 \*2 : Mode register setting can be set by 8 points through MODE register access. Default is “HOLD”.

### External Dimensions

The figure below shows the external dimensions of the FA-M3 with a 16-slot base module, excluding the power supply module.

Unit: mm

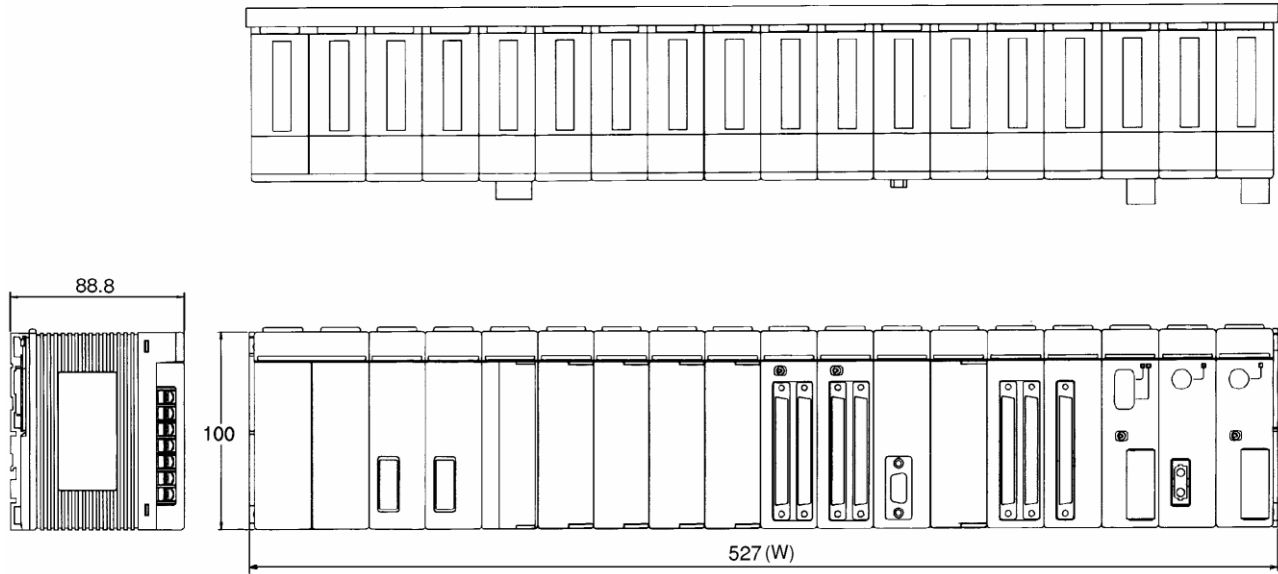

Base Module	Style	Number of Slots	Number of I/O Slots*	Width
F3BU04-0N	—	4	3	147 mm
F3BU06-0N	—	6	5	205 mm
F3BU05-0D	—	5	4	205 mm
F3BU09-0N	—	9	8	322 mm
F3BU13-0N	—	13	12	439 mm
F3BU16-0N	—	16	15	527 mm

- \*: Number of I/O slots that can be installed in a single CPU module.
- Mounting screw for securing optional modules on the base module: M4 × 12 mm
  - Note 1: Mounting screws are not provided with the base module. Four mounting screws are required for F3BU04, F3BU06 and F3BU05 modules. Four or five are required for F3BU09 and F3BU13 modules. Six or seven are required for the F3BU16 module.
  - Note 2: Mounting screw specifications:  
M4 binding head screw, 12-15 mm long (14-15 mm when a washer is used).
- These modules, except for the F3BU16 module, can be mounted on a DIN rail using the T9631AP and T9031AQ rail-mount kit.

### Approved / Compliant Standard:

For the UL-approved / CE Mark-compliant modules, see the General Specifications (GS 34M06C11-21E).

### Manufacturer's warranty

For FA-M3 manufacturer's warranty, see the following page.

[https://www.yokogawa.com/solutions/products-platforms/control-system/programmable-logic-controllers-plc-pac/fa-m3/#Details\\_Manufacturer-s-warranty](https://www.yokogawa.com/solutions/products-platforms/control-system/programmable-logic-controllers-plc-pac/fa-m3/#Details_Manufacturer-s-warranty)

For e-RT3 manufacturer's warranty, see the following page.

<https://www.yokogawa.com/solutions/products-platforms/control-system/ert3-embedded-controller/>